

Printed JAN 2010
1st Edition 1.01E

Foot-operated impulse sealer

FR-450 Series

Operating Instructions

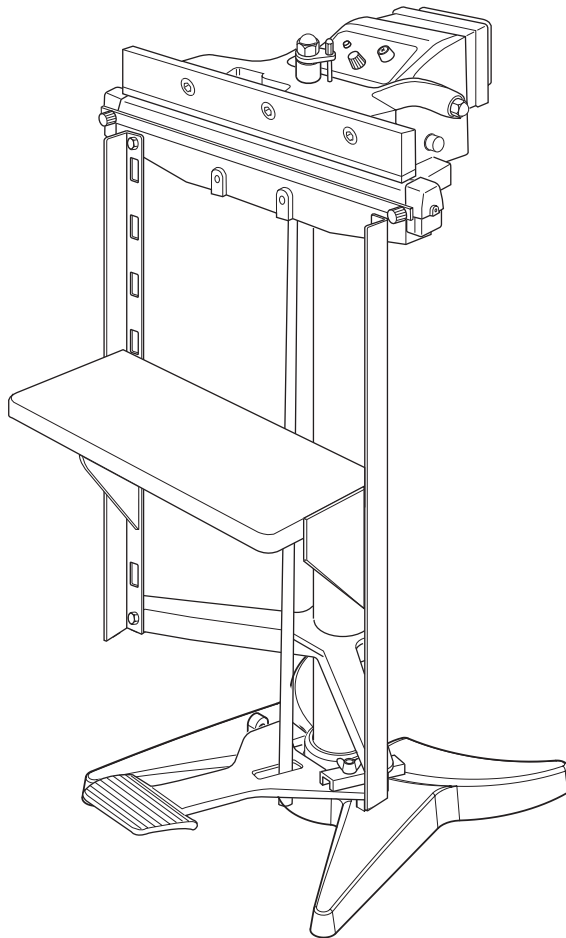

 **FUJI IMPULSE CO.,LTD.**



Foreword

Thank you for purchasing the Fuji Impulse FR-450 series sealer.

Please read all of the safety and operating instructions before operating this machine. Periodic maintenance and proper operation are necessary to ensure safety when using this impulse sealer.

Keep this manual on hand when operating the sealer.





Set the heating time according to the material and thickness of the film.

As a result of research to further improve the FR-450 series, some details in the operating instructions may differ from your actual machine. For operating problems or product information, please contact your local dealer or fax Fuji Impulse at (81)6-6335-5719.

About the warning labels

The warning labels indicate when there is a danger of injury to the operator or damage to the machine.

Below is a list of what each label denotes.

 Caution	Minor injuries or damages to the unit may occur when the instruction is ignored.
 Warning	Critical injuries or fatal accidents will almost certainly occur when the instruction is ignored.
 Danger	Critical injuries or fatal accidents will almost certainly occur when the instruction is ignored.
 Attention!	Important Notes and Restrictions - Read the directions in order to avoid misuse of the unit.
 TIPS	Great Tips and References when using the unit - Highly recommend reading through the information.

This manual is designed to cover machines of various voltages and plug configurations

Before using, always verify the voltage specification of your particular unit and operate it at the correct voltage.

Please note the following:

- 1) The voltage specification of your unit is listed on the label which displays the serial number. This label can be found on the machine body.
- 2) The explanations and illustrations in this operators' manual utilize the following standard plug configurations most common in Japan. However, due to the various configurations in use worldwide, these may not necessarily correspond with the one attached to your specific unit.



Voltages and plug configurations differ according to various worldwide specifications. Always verify those of your particular unit before beginning operation. Connecting the power cord to an outlet of a different specification is extremely hazardous.

Table of contents

1	Specification	5
2	Package contents	5
3	Replacement parts	6
4	Proper use of the sealer	6
5	Warning-caution label location and content	7
6	Operating precautions	8
	For safety operation	8
	For smooth operation	10
	Other safeguards	11
7	Major parts and function	12
8	How to assemble the sealer	13
	8-1 Install the v-shaped metal frame to the support pipe	13
	8-2 Install the support pipe to the stand base	13
	8-3 Install the sealer head	13
	8-4 Install the angle	14
	8-5 Straighten all the twisted parts	14
	8-6 Securely tighten the bolts for the v-shaped metal frame	14
	8-7 Install the rod and hook bar set	14
9	Proper use of the sealer	15
	9-1 Setting the machine	15
	9-2 Mounting the table	15
	9-3 Plugging in the electrical power cord	15
	9-4 Power switch ON	16
	9-5 Setting a sealing condition with the timer	16
	9-6 Place a pouch to the sealing area	16
	9-7 Depress the foot pedal	17
	9-8 Finishing sealing	18
	9-9 Power switch OFF	18
	9-10 Inspection after operation	18
10	Replacing the routine maintenance parts	19
	Preparation	19
	10-1 Sliding the Teflon sheet	20
	(For all models.)	20
	10-2 Replacing the heating element	21
	10-3 Replacing the glass tape and Sarcon sheet	23
	10-4 Replacing the silicone rubber	23
	10-5 Replacing the microswitch	24
11	Adjust the pedal height	25
12	About the optional hot stamp printer	26
13	About the optional clamping retaining device PK-101	26
14	Common problems and solutions	28
15	Electric diagram	30
	Exploded view and spare parts list	31

1 Specification

Code	Model	Voltage V	Power W	Sealing width mm	Sealing length mm	Weight kg	Machine dimension mm W x D x H	Options			Standard table
								Printer		Special Table	
								Inner	Outer		
-	FR-450-2	110	700	2	450	21	515×560×1040	○	○	○	○
-	FR-450-5	110	1150	5	450	22	515×560×1040	○	○	○	○
-	FR-450-10	220	2150	10	450	27	515×560×1040	○	○	○	○
-	FR-450-5W	110	1300	5	450	25	515 ×560×1040	○	-	○	○
-	FR-450-10W	220	2150	10	450	29	515×560×1040	○	-	○	○

2 Package contents

Please make sure that all of the accessories described below are included.

If not, please contact your dealer.

When the package is opened, make sure that the heating scale is pointing to 1.

If not, adjust heating dial so that the heating scale is pointing to 1.

Before using FR series of sealers, assemble the machine following to the directions of “8 How to assemble the sealer.”

Parts included for all model types

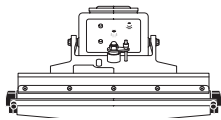

Sealer Head... 1 pc.

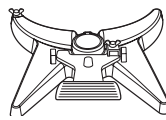

Stand Base ... 1 pc.

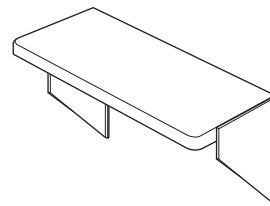

FR-450 Standard Table
... 1 set

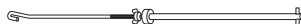

Rod and Hook Bar set
... 1 set



Support pipe ... 1 pc.



Heating Element
... 5 pcs.

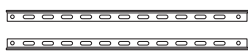

Angle ... 2 pcs.



Philips Screwdriver
... 1 pc.



Main Frame Mounting Bolt Set
... 1 set



Spanner Large and Small
... 1 pc. Each



Angle Mounting Bolt Set
... 1 set

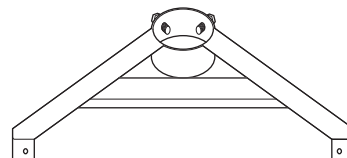

V-Shaped Metal
Frame ... 1 pc.

Parts for specific model types.

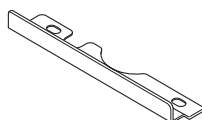

Seal Gauge
... 1 pc.

Seal gauge is included only in the accessories of FR-450-2 and FR-450-10.

Please noted that these illustrations are not reduced

3 Replacement parts

Routine maintenance parts, which will need to be replaced after extensive use, are sold individually as detailed below. Also the maintenance parts kits that includes all the consumable parts are available.

Replacement parts can be purchased through your local Fuji Impulse dealer.

Replacement parts sales unit

Parts Name	Sales Unit
Heating element	20 pcs./set or 10 pcs./set
Teflon	2 pcs./set
Silicone rubber	2 pcs./set
Glass tape	5M or 10M roll ... 1 roll
Sarcon sheet	2 pcs./set or 5M roll ... 1 roll
Plastic nut black 6mm	5 pcs./set
Microswitch	1 pc.
Microswitch cover	1 pc.

Maintenance parts kit detail

Models	Heating element	Silicone rubber	Teflon	Glass tape	Sarcon sheet
FR-450-2,5,10	3 pcs.	1 pc.	2 pcs.	5M roll/ 1roll	1 pc.
FR-450-5W(D),10W(D)	5 pcs.	1 pc.	2 pcs.	5M roll/ 1roll	1 pc.

4 Proper use of the sealer

- 1 The impulse sealer is a machine which sends strong electric current quickly to the thin ribbon heater, which presses against the film and instantly heat seals the package. Though this machine yields superior quality sealing, it is not compatible with films thicker than that indicated in the diagram below, sponge-like sheets, and materials which are not able to withstand high heat.
- 2 Film thickness limits for the FR-450 series are described below. The machine cannot seal bags which are thicker than that indicated. The machine may malfunction if you try to exceed the limits of the machine.

Heating method	Heater width	Film thickness (total thickness of piled film)
Single side heating	2mm	Less than 0.3mm
Single side heating	5mm	Less than 0.3mm
Single side heating	10mm	Less than 0.4mm
Double side heating	5, 10mm	Less than 0.5mm

5 Warning-caution label location and content

Warning - Caution labels are placed in locations where there is a danger of injury to a person or damage to the machine. Label location details are illustrated below. Please check them before beginning operation.

Labels not readily apparent are indicated by dotted lines.

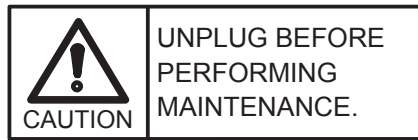

Adhered on the left side of the body frame.



When removing the timer, you will see this label adhered on the backside of the timer. Do not remove the timer unless it is necessary.

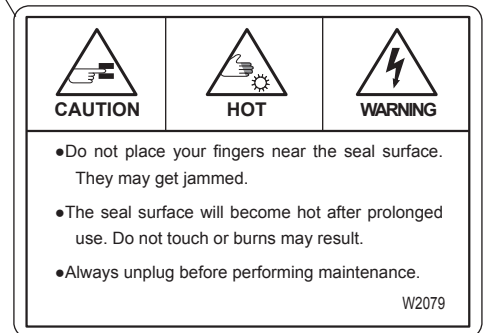
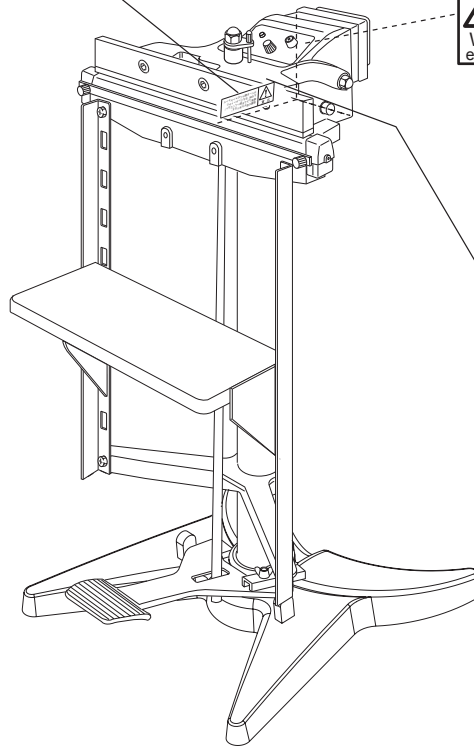

This label is adhered on the pressure lever.



If Warning - Caution labels peel off or are lost, please purchase the proper labels and place them in the appropriate location.

6 Operating precautions

For safety operation

 **Warning** In an emergency, unplug the power cord immediately

This sealer incorporates a number of safety devices and is carefully designed to prevent fires or other malfunctions. However, should all of the safety devices fail simultaneously, there is a possibility of the Teflon catching fire due to a failure of the heating circuit's tripping mechanism that results in the heating element overheating. Should smoke or fire appear from the Teflon, immediately release the foot pedal or turn OFF the power.

 **Warning** Confirm proper electric power source

Make sure power source has the specified voltage and electric power as explained in “1 Specification” of this manual. DO NOT use an extension cord, as the machine may malfunction due to voltage drop or may result in fire. Machine will malfunction if connected to anything other than the specified voltage.

Insert the electric power plug fully into the wall outlet.

 **Warning** Do not use for packaging liquids

Do not splash water on the machine or use machine for packaging liquids since machine is not waterproof. There is a danger of electrocution or malfunction of the machine.

 **Warning** Do not insert any metal objects into the sealing area

Please do not place any metal objects into the sealing area during operation. This could cause electrocution.

 **Warning** When replacing parts, unplug the power plug

Maintenance of the machine is important. Parts should be replaced in accordance with the operating instructions. There is a risk of danger if the parts are not replaced properly. Before replacing parts, unplug the machine from the power source and replace parts referring to “Replacing the routine maintenance parts” thoroughly.

 **Do not modify the machine**

Modification of the FR-450 series or the use of unspecified parts may not only lead to damage of the machine, but there is also a risk of danger to the operator. Please do not tamper with the machine. Accidents or damage caused by modification by the customer is the sole responsibility of the customer.

 **Do not use parts other than those specified**

When replacing parts, always use only specified parts sold through Fuji Impulse. Not responsible for malfunctions caused by the use of unspecified parts.

 **If the power switch automatically turns to the OFF position**

If after 4 seconds heating is not complete after it has been initiated, the power switch will automatically turn to the OFF position. There is a possibility of malfunction of the machine. Do not operate the machine until the cause of the shut down is ascertained and the problem has been addressed.

 **Do not use in the following places**

Do not operate machine in the following places since there is a danger of malfunction:

- 1 Dusty locations.
- 2 Locations not within normal temperatures.
- 3 Locations with high humidity.

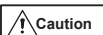
 **Do not place hands in the sealing area**

With prolonged use, the sealing area will retain heat and become hot. If you place your fingers in this area, there is a possibility of burns.

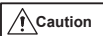
 **Use the machine properly**

Read “Proper use of the sealer” in this manual carefully and operate sealer correctly. Accidents or damage caused by misuse of the machine not in accordance with the operating instructions are the sole responsibility of the customer.

 **Run test trials first before beginning operation**

Achieving a superior seal with an impulse sealer is determined by heating / cooling / pressure strength. Depending on the type of film being used and the contents of the bag, heating / cooling / pressure strength conditions may drastically differ. Find the optimum sealing conditions by conducting seal tests before proceeding.

For smooth operation

- Heating temperature should be set at a minimum

Set sealer so that an acceptable seal is completed in the least amount of heating time. Excessively long heating times (increasing the heat setting unnecessarily) will damage the Teflon, glass tape and other consumables, as well as result in heating element breakage. This will lead to decreased work productivity and unnecessary power consumption.

- Allow sufficient cooling time

Cooling time is important when using an impulse sealer. After the film is heated, the film must cool with the frame and pressure lever in the closed position. After the heating lamp turns off, keep on depressing the pedal to let the bag cool in this position for 2-3 seconds. (The instructions are described in the “Proper use of the sealer>>>9-7 Depress the pedal” .)

- When the Teflon, silicone rubber becomes damaged

The Teflon, silicone rubber will start to wear with use. Once they are damaged, it will be difficult to achieve smooth and strong seals. Thoroughly read how to replace the parts and be careful when doing so.

- To achieve a strong seal

Proper sealing pressure is important in achieving a strong seal. Sealing pressure for FR series can be adjusted by the power to depress the pedal. Apply the optimum pressure when sealing.

- When operating machine for extended periods of time

The machine's temperature will rise upon prolonged use of the machine. As the temperature of the machine rises, the condition of the seal will change. Thus, heating time should be shortened and cooling time should be lengthened accordingly.

- Dust in the sealing area

Dust will prevent attainment of a smooth seal. It could also cause damage to heating element and/or other routine maintenance parts. Before using the machine, clean the sealing area.

Other safeguards

- Run test trials before beginning operation

Depending on the type of film being used, heating / cooling / pressure strength conditions will differ. Run test trials to find the optimum sealing condition, especially when trying to find the tightest seal possible.

- The Fuji Impulse FR-450 series is an impulse sealer

Do not become alarmed if the sealing area does not become hot after the power switch is turned to the ON position. The machine has not malfunctioned.

The Fuji impulse sealer uses an impulse method so the heating element will not become hot just by plugging the unit in or turning the power switch to the ON position. The heater will only become hot for an instant when the heating process is in operation. However, after extended periods of use, the sealing area may become hot.

- Printer outlet

The printer outlet is located on the underside of the seal frame head. It is to be used **ONLY** when mounting the optional printer.

Do **NOT** attempt to plug any other electronic devices into this outlet.

7 Major parts and function

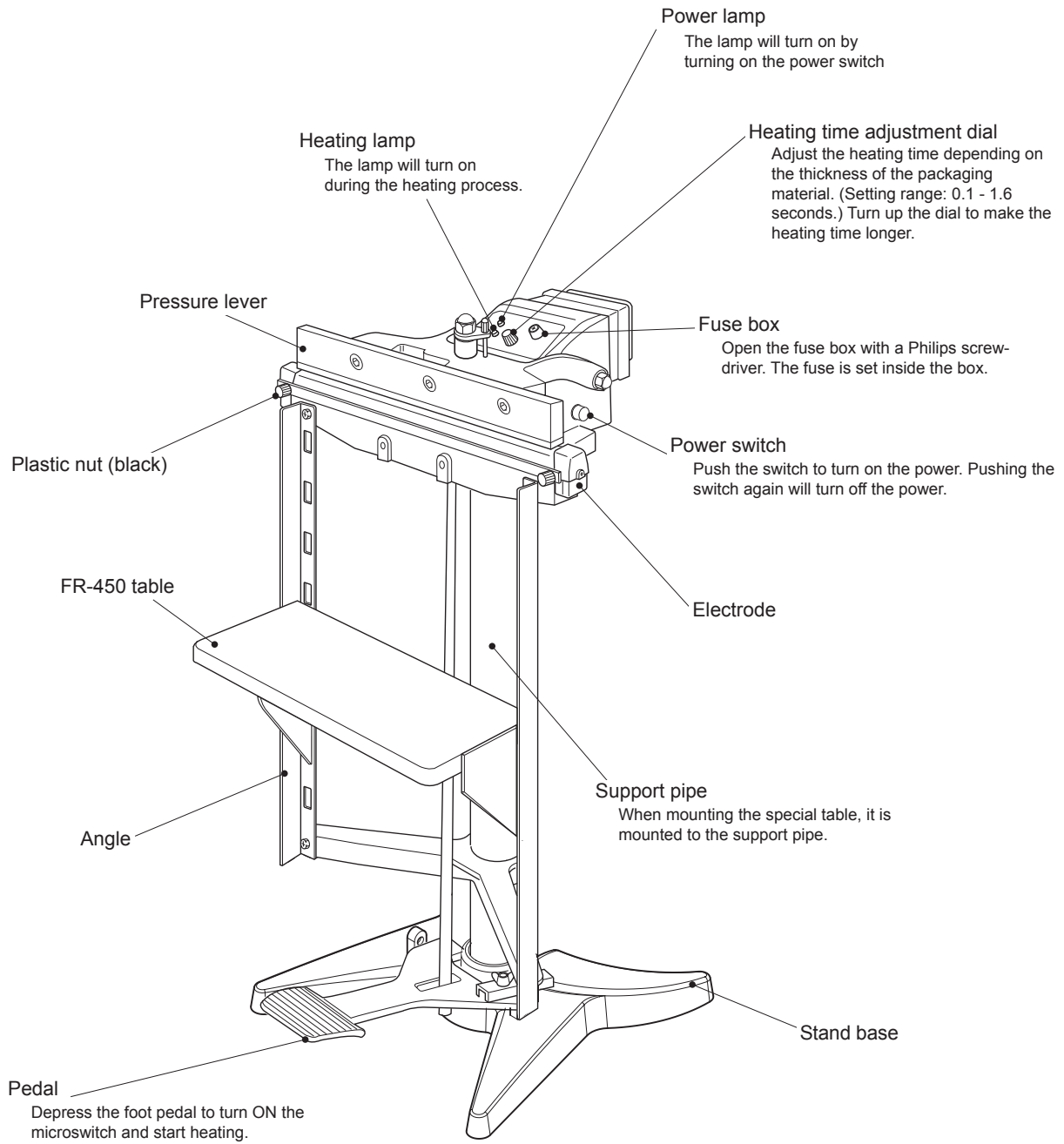

8 How to assemble the sealer

Please read the following "How to assemble the machine" thoroughly before starting assembling.

Assembling in the way ignoring this manual could cause malfunction or damage the machine and will be very dangerous.

After opening the package, please make sure that all the parts and accessories described in "2 Package contents" are included.

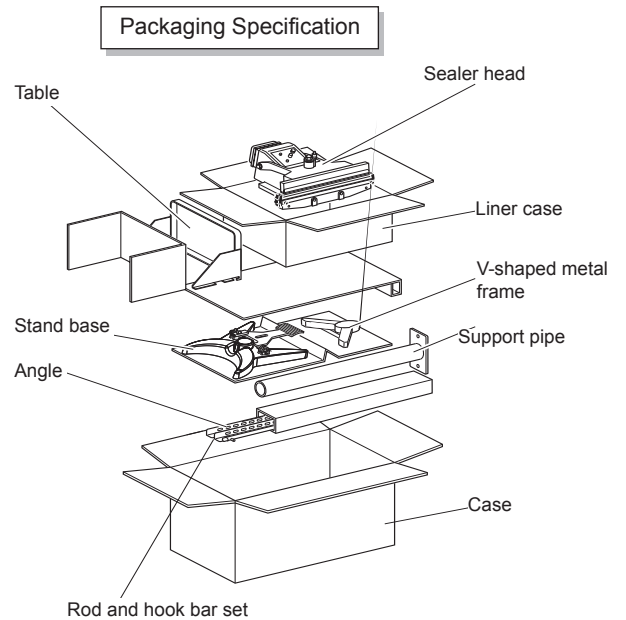

Please noted that the rod and hook bar set is in the partition box.

8-1 Install the v-shaped metal frame to the support pipe

Insert the support pipe to the hole of the v-shaped metal frame, and temporarily tighten the hexagon head bolt.

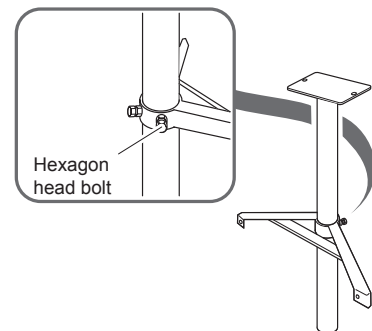

8-2 Install the support pipe to the stand base

Insert a support pipe into the hole of stand base, and temporarily tighten the set bolt.

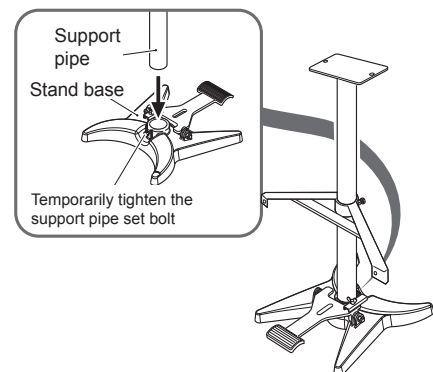

8-3 Install the sealer head

Adjust the screw holes of the support pipe stand and the sealer head to make them overlap, and lock with the attached bolt set (fixing bolt, lock washer, nut).

Do not tighten the setting bolt completely yet.

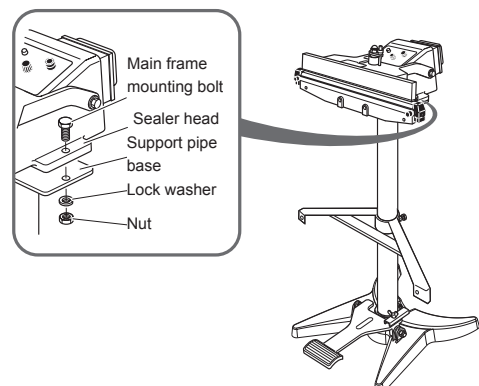

8-4 Install the angle

Using the angle mounting bolt set, fix the upper part of the angle to the seal frame. Fix the lower part to the v-shaped metal frame.

8-5 Straighten all the twisted parts

Straighten the sealer head so it is set parallel to the stand base, and securely tighten the temporarily fixed bolts at the procedures before 8-3.

8-6 Securely tighten the bolts for the V-shaped metal frame

■ Final tightening order ■

- 1 Main frame mounting bolt (2pcs.)
By installing the table to the angle, it will be easier to set the sealer head parallel to the base.
- 2 Support pipe set bolt (1 pc.)
- 3 Hexagon head bolt for installing the v-shaped metal frame (2 pcs.)
After the final tightening, remove the table from the angle.

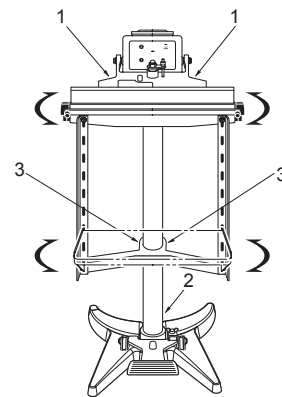
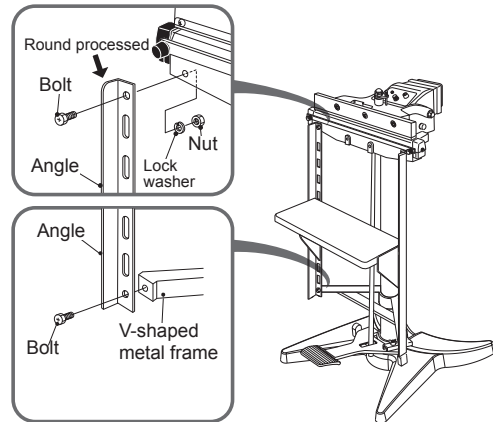

8-7 Install the rod and hook bar set

Set the large pressure spring to the seal frame. Next, insert the sliding shaft lifter into the large pressure spring.

As the rod adjusting nut is adjusted at the optimum level and fixed with the wing nut, the adjustment is not required. When you would like to adjust the pedal height, please refer to “11 Adjust the pedal height.”

Hang the hook of the rod/ hook bar set on the sliding shaft lifter. Then insert the pin on the other end of the bar to the pedal hole and fit the pin into the groove at the backside of the pedal.

■ Assembling complete ■

Please refer to the machine illustration on the cover of this manual for the as-built drawing.

Also please refer to “9 Proper use of the sealer”, and use the sealer properly. The table installation procedure is explained in “Proper use of the sealer.”

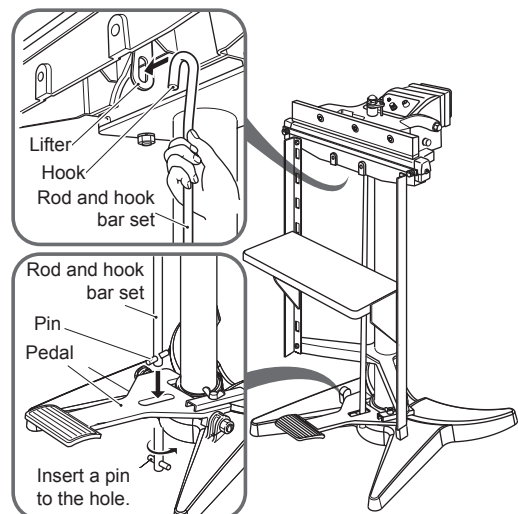
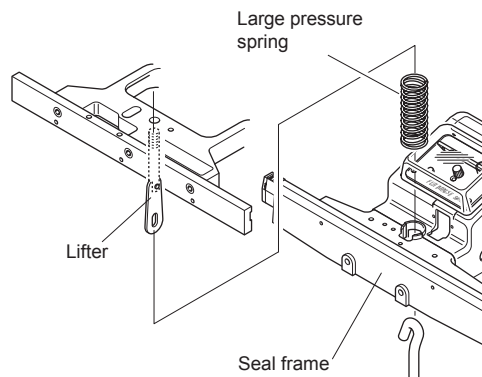

9 Proper use of the sealer

Before using the Fi/FiK series, read “8 How to assemble the sealer” thoroughly and properly assemble the sealer head, support pipe and stand base. Also use the sealer only as described in below “Proper use of the sealer”. There is a risk of danger and malfunctions if the machine is not used in accordance with this manual.

9-1 Setting the machine

Place a machine on a flat, horizontal surface.



Installing the machine on an unstable or inclined surface may cause the overturn of the sealer.

Loosen the wing nut fixed to the rubber feet with bolt to adjust the height of rubber feet to accommodate to some uneven surface.

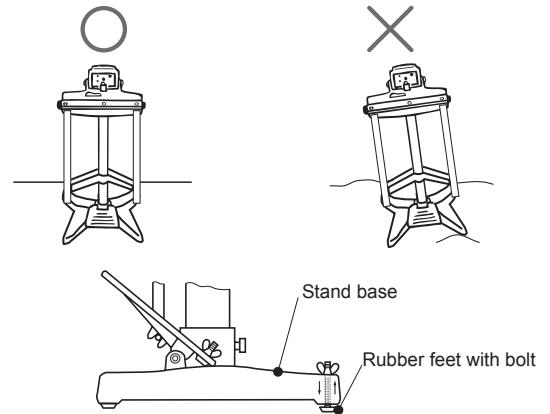

9-2 Mounting the table

If the table is not necessary, you do not need to perform this process.

Secure the special table for FR-450 series by inserting the hook of the table to the holes of the angle at the optimum position depending on the application of use.

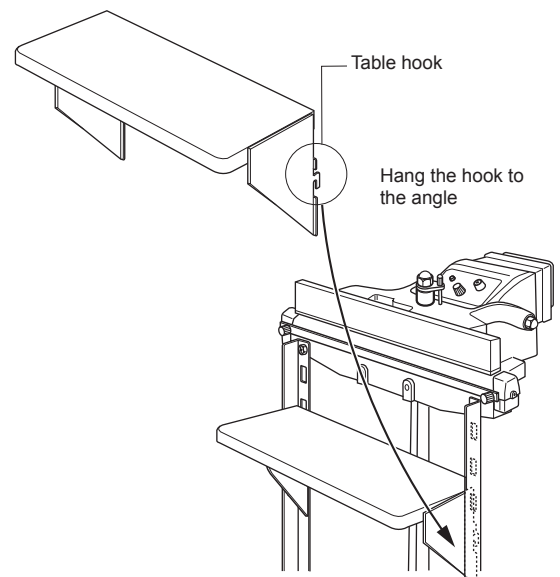

9-3 Plugging in the electrical power cord

The power cord is located on the right side of the machine, when facing toward it. Make sure the electrical outlet has adequate current carrying capacity as described at “1. Specification.” Insert the electric power plug fully into the wall outlet.



There is a danger of fire if the electrical power source does not meet proper specification.

9-4 Power switch ON

The power lamp for the timer will turn on when the power switch, located on the side of the common frame is pushed on.



Turning ON the power switch



9-5 Setting a sealing condition with the timer

Set the heating time with the timer.

The setting will differ depending on the type or thickness of your packaging material. Change the setting every time you change the packaging material.

- Set the heating time

Turn the heating time adjusting knob to set the heating time. [Setting range: 0.1 - 1.6 seconds]

The heating time differs depending on the film/pouch.

Set the heating time at a minimum required to make a sufficient sealing to increase work productivity and avoid unnecessary power consumption.

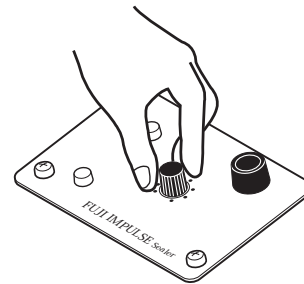
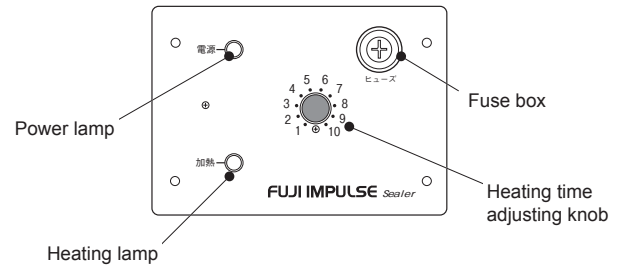

Warning There is a danger of fire if the sufficient cooling time explained in “9-7 >>3” is not allowed when using the sealer for an extended period of time.

9-6 Place a pouch to the sealing area

Hold a pouch with both hands and stretch it tight to avoid wrinkles to the sealing surface.

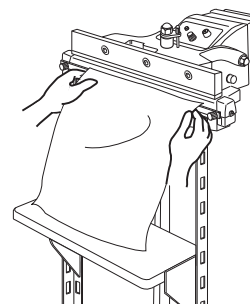

9-7 Depress the foot pedal

Cooling time is important when using an impulse sealer. After the film is heated, the film must cool with the frame and pressure lever in the closed position. After the heating lamp turns off, keep on depressing the pedal for 2 - 3 seconds to let the film be cooled off.

- 1 Depress the foot pedal until you hear the click sound of the microswitch being activated. Heating lamp will turn on and the heating process begins.

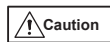

Do not depress the pedal more than necessary as there is a danger of damaging parts such as a microswitch. Make sure not to compress the pressure rubber lower than 22mm in height.

- 2 After passing the heating time, the heating lamp will be turned off.

- 3 Keep on depressing the pedal for 2 - 3 seconds after the heating lamp turned off to allow sufficient cooling time.

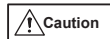

If the cooling time is not enough, the seal will become messy and damage the parts. For the better seals, allow sufficient cool time for each cycle.

Please find the most suitable conditions as you do test sealing.

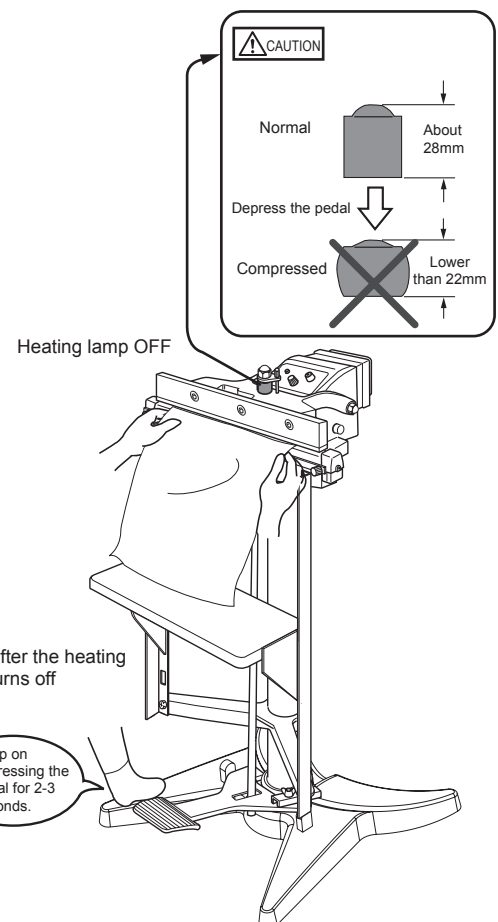
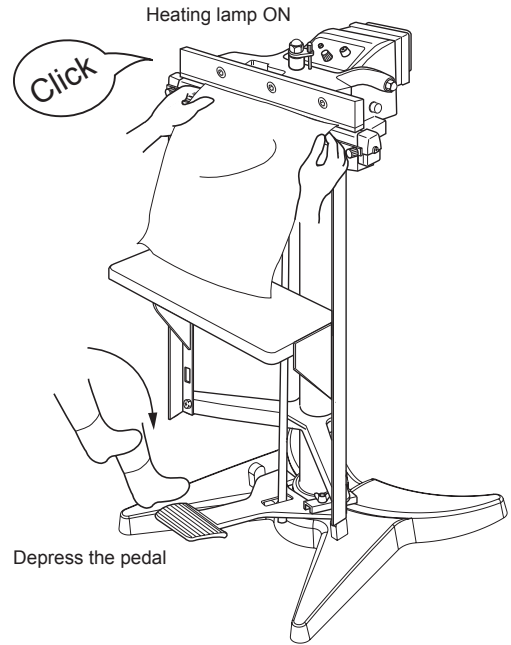

9-8 Finishing sealing

After the heating and cooling cycle has finished, release the foot pedal and the sealing is complete.

If a sealing is not clean enough, adjust the heating time or change the strength to depress the foot pedal.

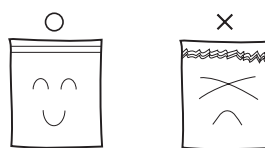

9-9 Power switch OFF

After finishing operation, always turn OFF the power switch.

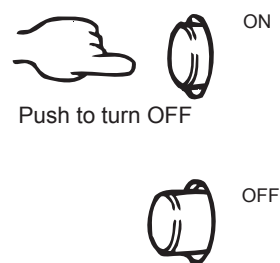

Unplug the power outlet in the case of not using the machine for a while.

9-10 Inspection after operation

After use, please clean up the parts. Inspect parts such as Teflon and heating element to make sure that they are not damaged. If the parts appear to be damaged, replace them referring to operating instructions.

10 Replacing the routine maintenance parts

Daily maintenance or replacement of parts at an early stage can prevent the machine from being damaged, and keeps the machine at the optimum condition. Replace parts according to the following directions in order to maintain your machine in optimum operating condition.



Always unplug the power plug before replacing parts. There is a danger of electrocution if it has been done without unplugging.



Follow the directions on this manual when replacing parts. Replacing parts in the way ignoring this manual could cause malfunction of the machine as well as electrocution and fire.



Always use only specified parts sold through Fuji Impulse. Unspecified parts may cause malfunction of the machine.



Always unplug the machine before maintenance.

Structure of the sealing section

The sealing section consists of the parts as in the illustration below. When replacing parts, be careful to arrange the parts exactly in the same order.

Single side heating

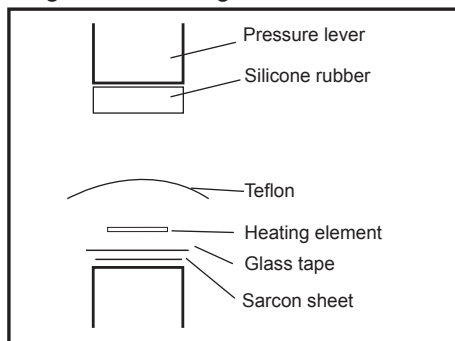

Double side heating

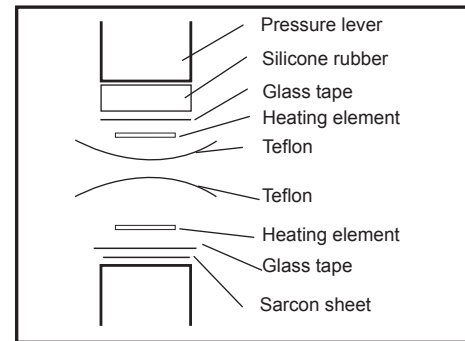

Preparation

•Before replacing parts

When replacing parts, lift up the pressure lever for easier replacement.

How to lift up the pressure lever

Push down the pressure lever to remove the hook bar from the sliding shaft lifter. Now you can lift up the pressure lever.



When the pressure lever is lifted up, you can activate the microswitch by clicking it with a thin stick, etc. Do not activate the microswitch as it will start heating and may result in fire if the plug is not unplugged.

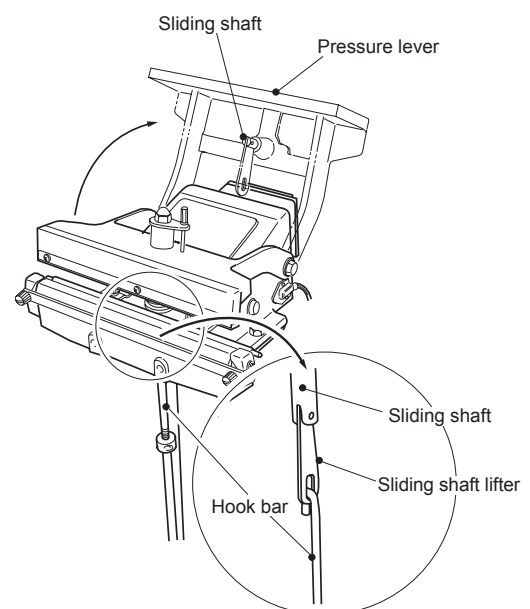

10-1 Sliding the Teflon sheet

Essential tools: Scissors, a Philips screwdriver

Replace when: The Teflon, burns, or when the seal becomes messy, etc.

Teflon is either sold individually or included in the maintenance parts kit. It is rolled to the Teflon roll bar about 25 - 30cm as an extra.

• Lower Teflon (for all types)

- 1 Loosen two black plastic nuts at the front side of the machine to remove the lower Teflon sheet holding plate.
- 2 Loosen two black plastic nuts that fix the Teflon roll bar so it can be moved, and slide the Teflon toward you.
- 3 Cut the damaged Teflon with scissors.
- 4 Insert the edge of the Teflon between the lower Teflon holding plate and Teflon sheet holder support. And then fix the lower Teflon sheet holding plate with black plastic nuts.
- 5 Roll up the Teflon to the Teflon roll bar so it does not wrinkled.
- 6 Tighten the black plastic nuts to secure the Teflon toll bar with Teflon roll bar fastening plates.

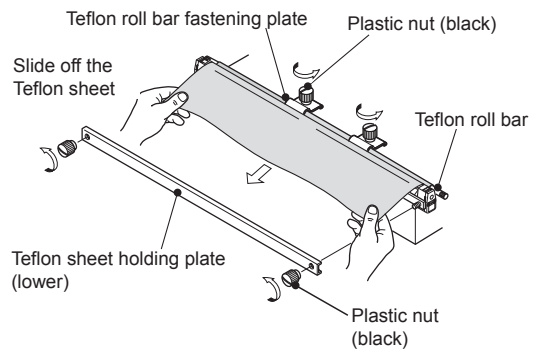

• Upper Teflon (for the double heating type)

- 1 Loosen the two white nuts at the backside of the pressure lever so the Teflon roll bar can be moved.
- 2 Loosen the screws that fix the upper Teflon sheet holding plate and slide the edge of the Teflon to the direction indicated by the arrow.
- 3 Cut the damaged Teflon with scissors.
- 4 Insert the edge of the Teflon between the upper Teflon sheet holding plate and pressure lever and tighten the screws to secure the upper Teflon sheet holding plate..
- 5 Roll up the Teflon to the Teflon roll bar so it does not wrinkled.
- 6 Tighten white plastic nuts loosened at the procedure 1 to secure the Teflon roll bar with the Teflon roll bar fastening plates.

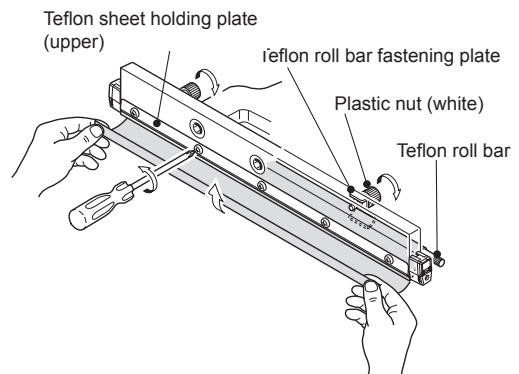

10-2 Replacing the heating element

Electrodes that mount the heating element consist of parts as in the right illustration.

Warning If you loose the screw C, do not substitute ones longer than the screw C (M4x6) as there is a danger of short circuit by the longer screw touching screw D.

Warning When replacing the heating element, replace the glass tape and Sarcon sheet as well if they appear to be damaged. If they are damaged and cannot properly insulate the heating element from the body frame, the short circuit may result.

TIPS The heating element can be replaced without removing the electrode cover so you will not loose the cover or screw.

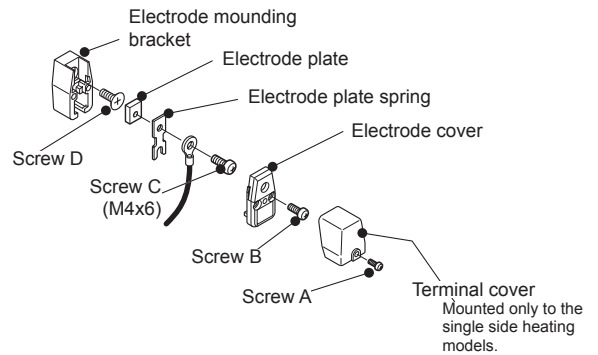

- How to replace lower heating element

Essential tools: A Philips screwdriver

Replace when: The heating element breaks, unevenness is generated, or when the seal becomes messy.

The heating element is either sold individually or included in the maintenance parts kit.

- 1 Remove the Teflon sheet. (Refer to “10-1 Sliding the lower Teflon sheet.”)
- 2 Loosen the screw A of both electrodes with a Philips screwdriver, and remove the terminal covers. The illustration on the right describes the electrode without the terminal cover.
- 3 Loosen screw B of both electrodes to loosen the tension of the heating element. It is not necessary to remove the electrode covers.
- 4 Insert a Philips screwdriver into the hole of the electrode cover and loosen screw C. The heating element can be removed.
- 5 When mounting a new heating element, insert each terminal between the electrode plate and electrode plate spring. While pushing down the terminal with your fingers so it stays in place, tighten screw C with a Philips screwdriver.
- 6 Tighten the screw B loosened at the procedure 3 so the heating element is stretched tight. When the screw B is not tightened enough, the heating element will not be stretched tight enough, which may result in damaging it.
- 7 Fix the terminal covers to the electrodes with screw A.

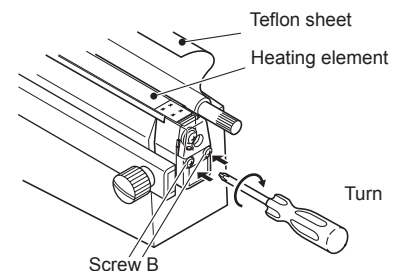

Caution Without loosening the screw B, the heating element will be kept stretched tight. Thus the heating element terminal cannot be inserted between the electrode plate and plate spring.

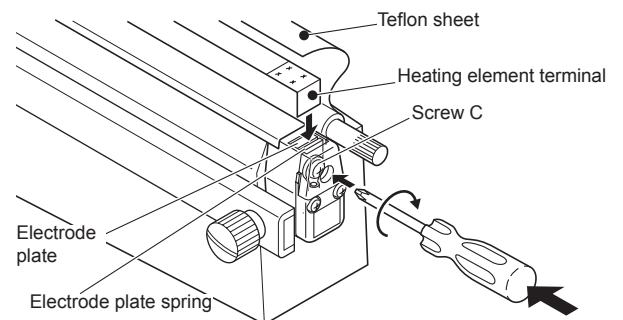

Turn while pushing

● How to replace upper heating element

Essential tools: A Philips screwdriver

Replace when: The heating element breaks, unevenness is generated, or when the seal becomes messy.

The heating element is either sold individually or included in the maintenance parts kit.

- 1 Remove the Teflon sheet. (Refer to “10-1 Sliding the Teflon sheet.”)
- 2 Loosen the screw B to release the tension of the heating element.
- 3 Insert a Philips screwdriver to the hole of the electrode to loosen the screw C. The heating element can be removed.
- 4 When mounting the new heating element, insert each terminal between the electrode plate and electrode plate spring. While pushing down the terminal with your fingers so it stays in place, tighten the screw C with a Philips screwdriver.
- 5 Tighten the screw B loosened at the procedure 2 so the heating element is stretched tight. When the screw B is not tightened enough, the heating element will not be stretched tight enough, which may result in damaging the heating element.)

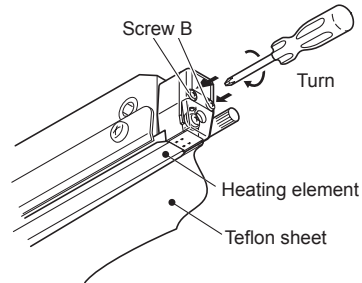

Without loosening the screw B, the heating element will be kept stretched tight. Thus the heating element terminal cannot be inserted between the electrode plate and plate spring.

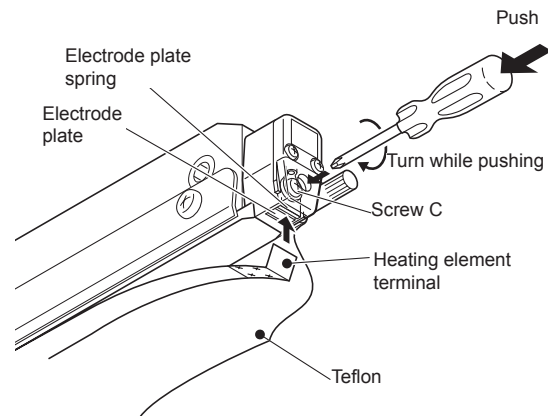

10-3 Replacing the glass tape and Sarcon sheet.

Essential tools: Scissors, a Philips screwdriver

Replace when: The heating element breaks often, the seal becomes messy, etc.

The glass tape and Sarcon sheet are either sold individually or included in the maintenance parts kit.

- 1 Carefully read “10-1 Sliding the Teflon sheet” and “10-2 Replacing the heating element,” and remove them.
- 2 Completely remove the glass tape and Sarcon sheet under the heating element.

Attention! Applying the Sarcon sheet and glass tape to a surface with adhesive residues will negatively affect the sealing surface.

- 3 Cut the new Sarcon sheet 2mm longer than the seal area for left and right sides and adhere it to the lever.
- 4 Adhere the glass tape over the Sarcon sheet so it covers the electrode about 5mm.

Attention! If the adhesive of the Sarcon sheet is weak when replacing the glass tape, please replace the Sarcon sheet as well.

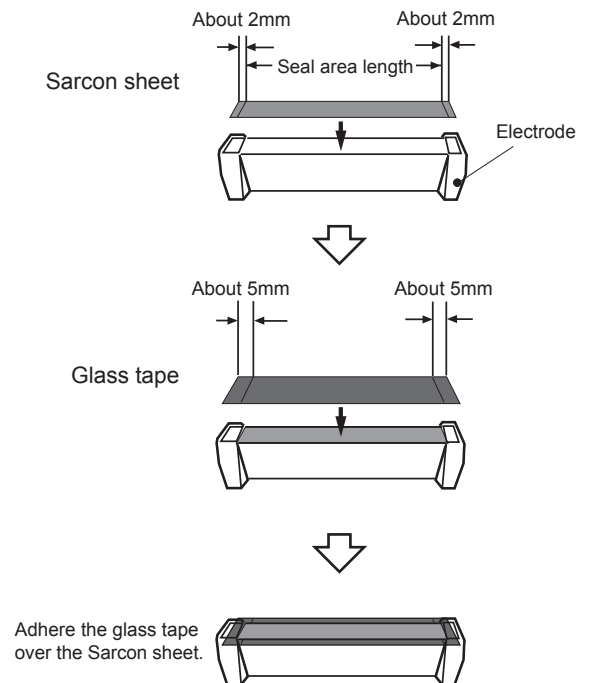

10-4 Replacing the silicone rubber

Essential tools: Industrial-purpose alcohol (Ethanol)

Replace when: The seal becomes messy, etc.

The silicone rubber is either sold individually or included in the maintenance parts kit.

- 1 Remove the damaged (old) silicone rubber.
- 2 Using an industrial purpose alcohol, etc., completely remove the adhesive residues remaining on the metal portion of the pressure lever.
- 3 Adhere the new silicone rubber starting from the edge.

Attention! Adhere the silicone rubber carefully as it cannot be reapplied.

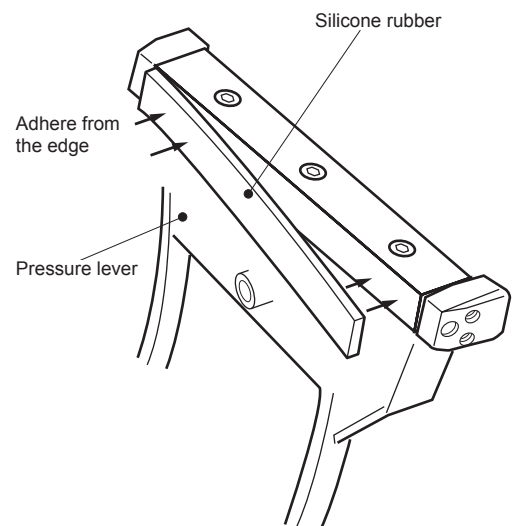

10-5 Replacing the microswitch

Essential tools: A Philips screwdriver

The microswitch is sold individually.

 **Warning** Always unplug the power cord from the outlet when replacing the microswitch.

- 1 Referring to “10 Replacing the routine maintenance parts >>> Preparation,” lift up the pressure lever.
- 2 Loosen the screws that fix the microswitch case to the common frame, and remove the microswitch case.
- 3 Next, loosen the screws that fix the microswitch, and remove it from the microswitch case.
- 4 Remove all of the cables.

Installation

- 5 When reattaching the microswitch, wire properly referring to “15 Electric diagram.” If the wiring is not correct, the timer may be damaged.

 **Warning** If the wiring of the microswitch is not correct, the timer may be damaged. Regarding the triac connection, the label is adhered to the timer.

- 6 Attach the microswitch to the microswitch case removed at the procedure 3 using the screws. Please refer to the illustration on the right for how to install to the microswitch case.
- 7 Attach the microswitch case to the common frame.
- 8 Return the pressure lever etc. removed at the procedure 1 to the initial state.

 **Warning** If you activate the microswitch by pushing it with a thin object, it may bring the heat to the heating element and there is a danger of burning or fire.

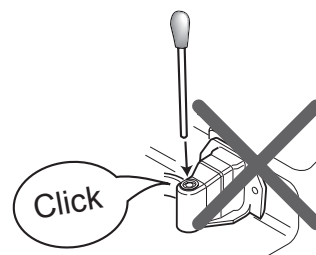
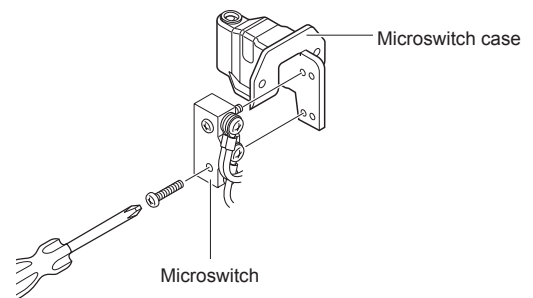
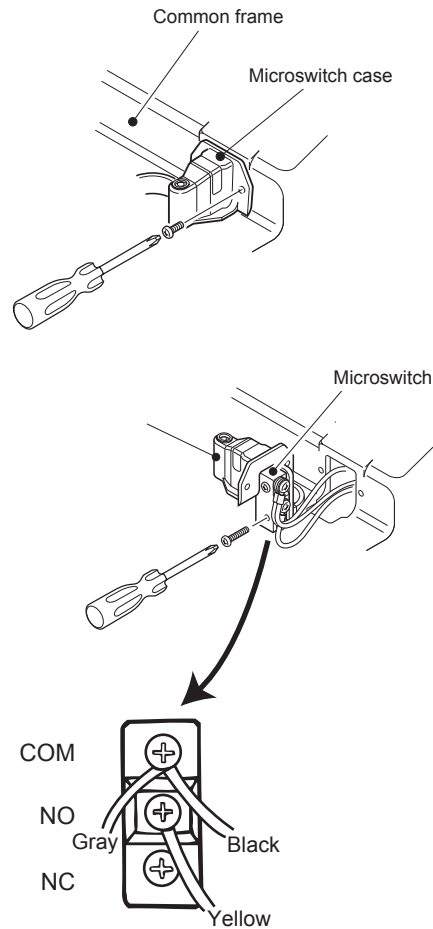

11 Adjust the pedal height

Adjust the pedal height (angle) by turning the rod adjusting nut.

- 1 Loosen the wing nut on the rod adjusting nut.
- 2 The pedal will go down when the rod adjusting nut is tuned counterclockwise.
- 3 The pedal will rise when the rod adjusting nut is turned clockwise.
- 4 After finishing the adjustment, tighten the wing nut to fix the rod adjusting nut.



If the rod adjusting nut is turned too much, the microswitch will not be activated or the sealer may fall when depressing the pedal. Please do not turn the rod adjusting nut too much.

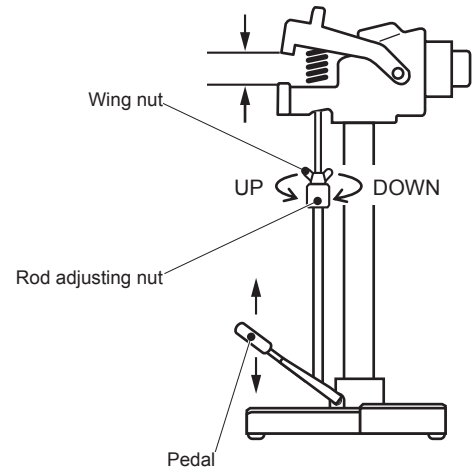

12 About the optional hot stamp printer

- Optional hot stamp printer can be installed to the FR-450 series of sealers.
- Manufacturing date and lot number etc. can be printed at the same time as sealing.
- There are two types for FEP-N1 series: One is inner printing type that prints below the sealing surface, and the other is outer printing type that prints above the sealing surface.

Models	Inner printer		Outer printer	
	Code	Name	Code	Name
FR-450-2, 5, 10	05201B	FEP-N1	05202B	FEP-OS-N1
FR-450-5W (D), 10W (D)	05201B	FEP-N1	x	

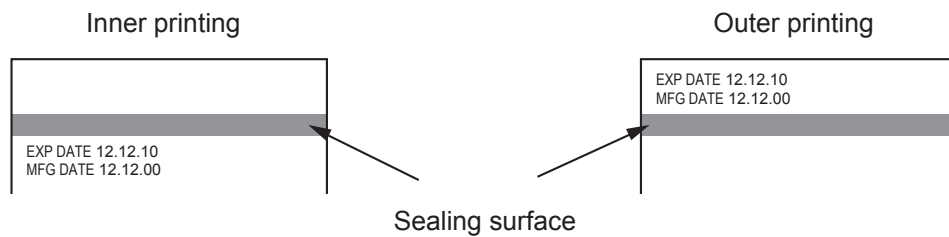

13 About the optional clamping retaining device PK-101

PK-101 can be installed to precisely even out the sealing finish and to effectively resolve the problem of user fatigue from operating the pedal by foot.

The user can set the cooling time (i.e., clamping retention time) and the pressure on film that have a major effect on the impulse sealer's sealing finish. These cannot be set using the timer on the sealer. It is recommended to use the PK-101 with your foot-operated sealers. For the installment method, please refer to the PK-101 operating instructions.

How to operate PK-101

- 1 Lightly depress the pedal.
- 2 A solenoid works automatically to retain the pressure.
- 3 After heating, the PK-101 retains the pressure during the set cooling time. It is not necessary to keep on depressing the pedal.
- 4 After finishing cooling, the pressure is automatically released and the lever returns to the initial position.

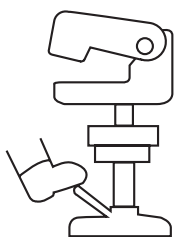

1 Depress the pedal.

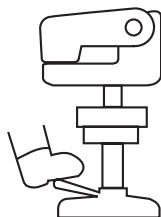

2 Retains the pressure.

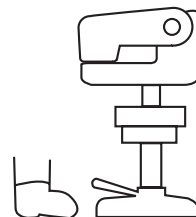

3 During heating and cooling process.

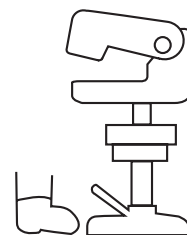

4 Sealing is complete. the lever returns to the initial position.

14 Common problems and solutions

If you are experiencing problems with the machine, please refer to the chart below.

Carefully follow the directions in the operating instructions when replacing parts.

Please consult your dealer or Fuji Impulse if after referring to the chart, the problem cannot be resolved.

Please refer any questions regarding replacement of parts not listed in the operating instructions or adjustment of such parts to your dealer or Fuji Impulse.

Items marked with an asterisk ※ in the “Solutions” column refer to the fact that these problems should be addressed by an electrician. If there are any problems, please contact your dealer or Fuji Impulse.

 **Warning** Always unplug the power plug before replacing parts.

Problems	Check	Solutions
The heating lamp does not turn on even after turning On the power switch.	Does the electricity come to the outlet?	Make sure that the electricity comes to the outlet.
	Is the power plug fully plugged in?	Insert the power plug fully to the outlet.
	Is the power plug damaged?	*Replace the power cord or power plug.
	Is the power cord disconnected?	
	Is the fuse inside the timer box blown?	Replace the fuse.
The power lamp turns ON, but the heating lamp does not turn on and sealing cannot be made even though depressing the pedal.	The foot pedal is not depressed enough.	Depress the foot pedal until you hear the click sound of the microswitch being activated.
	Is the rod adjusting nut turned to the direction of "DOWN" too much to activate the microswitch?	Turn the rod adjusting nut to the direction of "UP." (Refer to "11 Adjust the pedal height.")
	-----	*The microswitch may be damaged. Replace the microswitch.
The heating lamp turns on, but there is no heat and sealing cannot be made.	Is the heating element severed?	Replace the heating element.
	The electrical contact of the electrode and heating element is bad.	Polish the part where the electrode and heating element contact with the sandpaper.
	Is the black (blue) cable from the transformer to the electrode securely wired?	*Securely wire the black (blue) cable from the transformer to the electrode.
	-----	*The triac inside the timer may be broken. Replacement is required.
Heating element easily breaks.	Is the heating time set too long?	Set the heating time at a minimum required to make a sufficient seal.
	Do you release the foot pedal while the heating lamp is on or soon after it turns off? (Cooling time is not enough.)	Release the foot pedal after 2 - 3 seconds after the heating lamp turns off.
	Is the glass tape or Sarcon sheet damaged?	Replace the glass tape or Sarcon sheet.

Problems	Check	Solutions
The heating element bends at the center and breaks.	Is the electrode damaged?	*Replace the electrode.
	The foot pedal is depressed too hard.	Depress the foot pedal little lighter.
	The surface of the silicone rubber is uneven.	Replace the silicone rubber.
Sealing is not clean.	Have the pressure lever and seal frame become hot? (As the temperature of the pressure lever and frame rises, the film may melt without changing the heating time.)	Wait until the pressure lever and frame being cooled off, and take enough operation interval.
	Are the Teflon, glass tape, Sarcon sheet and silicone rubber damaged?	Replace the Teflon, glass tape, Sarcon sheet and silicone rubber.
	Are you releasing the foot pedal while the heating lamp is still on or soon after it turns off? (Cooling time is not enough.)	Release the foot pedal after 2 - 3 seconds after the heating lamp is turned off.
Sealing results in uneven on the right and left side. (Melts on one side.)	The surface of the silicone rubber is uneven.	Replace the silicone rubber.
	When depressing the pedal fully, do you recognize the gap between the pressure lever and seal frame?	If you do, please contact your local dealer or Fuji Impulse as the machine needs to be repaired.
Heating lamp continues to be turned on and the heating element and Teflon burn.	----	* The timer or power switch may be damaged and replacement of those parts is required.

Solutions marked with an asterisk * mark should be addressed by electrician or experts in replacing electric parts. If you have any troubles in solving the problems, please contact with your local dealer or Fuji Impulse.

15 Electric diagram

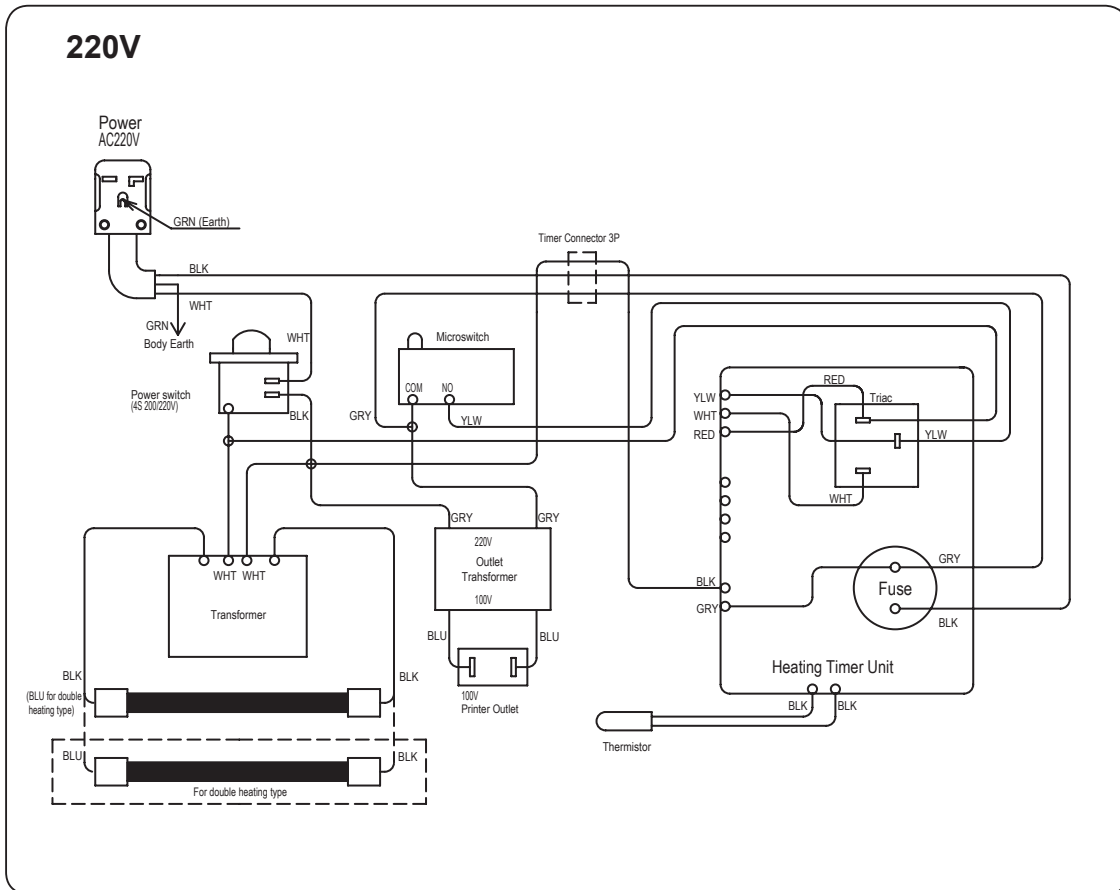
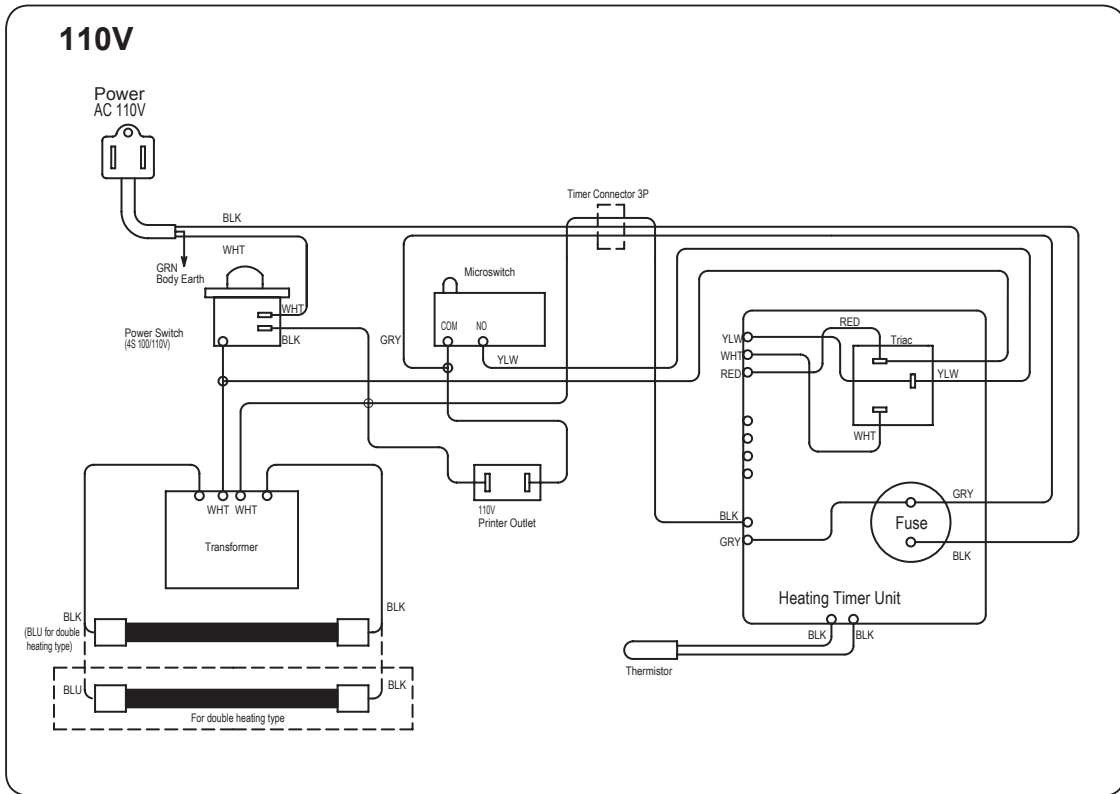

Refer to the exploded view and spare parts list for the electric parts.

Exploded View Spare Parts list

When ordering spare parts, please consult the exploded view diagram/spare parts list on the following pages and provide both the part name and code number to your local dealer.

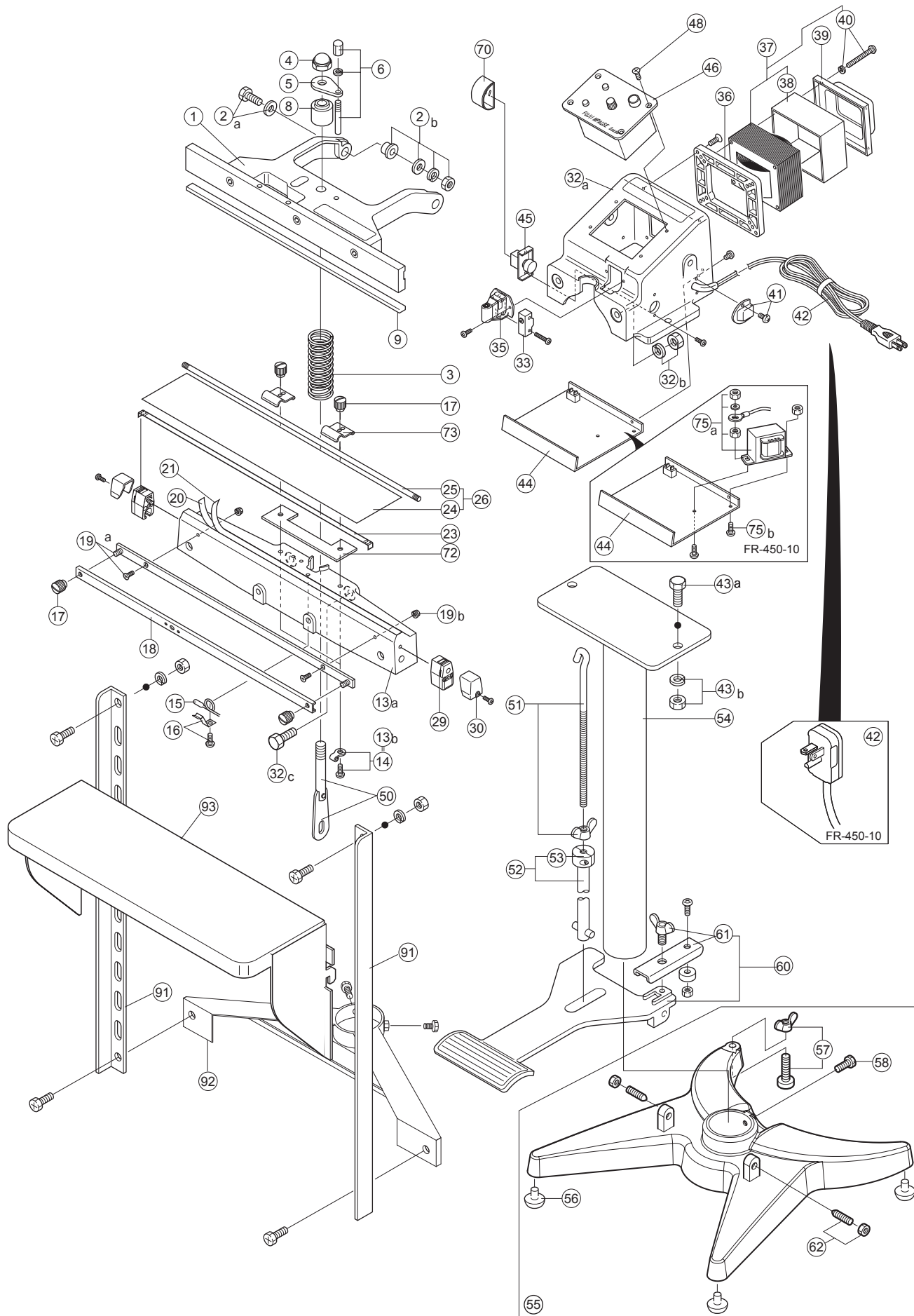

FR-450 W (D) Series Exploded View

F Type
FR-450-5W

F Type
FR-450-10W

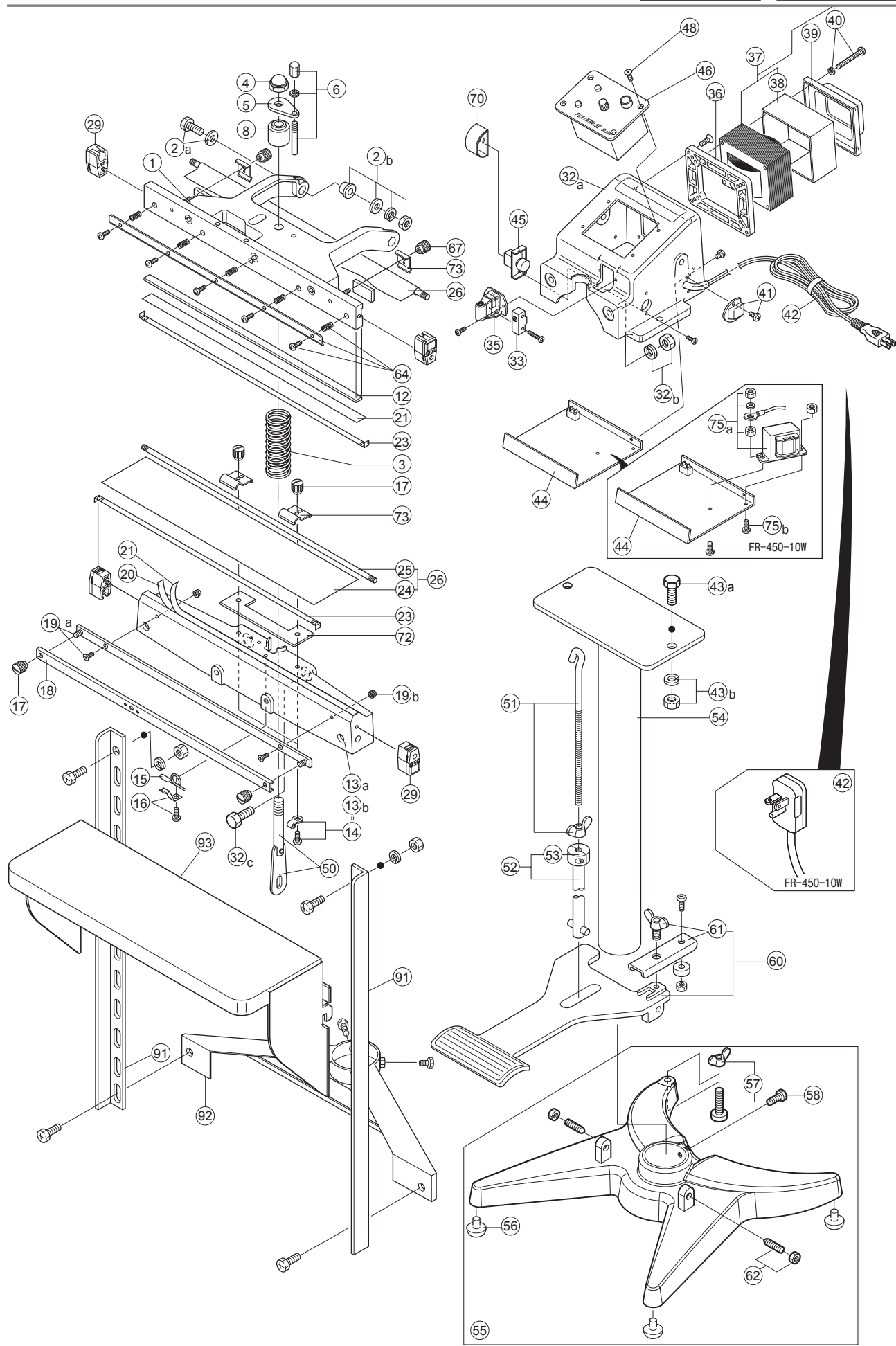

Y6597 AUG 2009 1st Edition

FR Series Operating Instructions Ver1.01E