

## 9 Replacing the routine maintenance parts

Replace parts according to the following directions in order to maintain you machine in optimum operating condition.



Do not replace parts according to other methods not described in the operating instructions.

It is dangerous if incorrect methods are used.



Always unplug power plug before replacing any parts. There is a danger of electrocution if conducted with the plug still inserted.

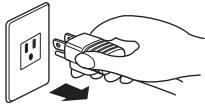

Always unplug power plug from the wall outlet before conducting any maintenance.

### Construction of the sealing area

The sealing area is constructed with parts illustrated in the diagram below.

When replacing parts, be careful to arrange the parts in the same exact order.

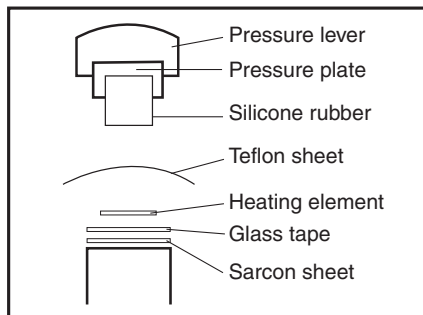

## 1 Slide the teflon sheet

[Essential tools] Scissors

[Replace when] When the teflon sheet is torn, burnt or sealing is dirty.

Teflon sheet is sold separately, and included in spare parts set.

- 1 Remove the table from the holder by removing two plastic nuts (white) under the table.
- 2 Loosen the plastic nut (white) tightening the teflon roll bar so that it can rotate.
- 3 Pull the teflon sheet forward until a new portion covers the heating element. (to the direction of allow)  
Cut off the old portion with scissors and discard.

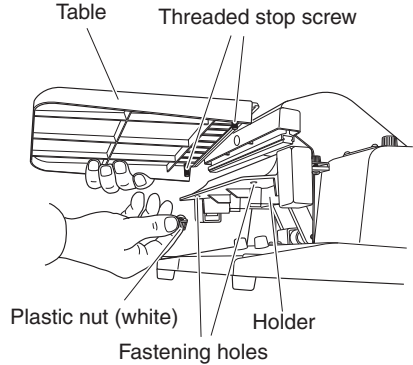

**TIPS** Since the end of teflon sheet has to be fastened between table and holder, Please leave the enough length to insert before cutting.

- 4 Install the table as described in "8 Proper use of the sealer / 2" with binding the end of teflon sheet between table and holder.

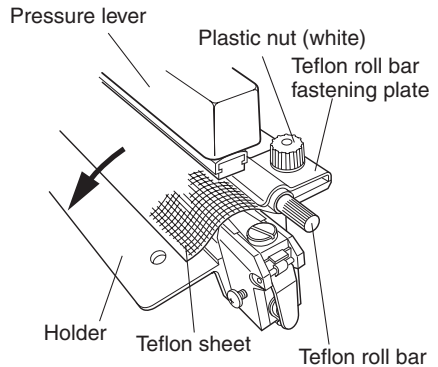

## 2 Change the heating element

[Essential tools] Screwdriver (-)

[Replace when] The heating element has burned out.  
Sealing is uneven or dirty,  
etc.

Heating element is sold separately and included in the spare parts set.

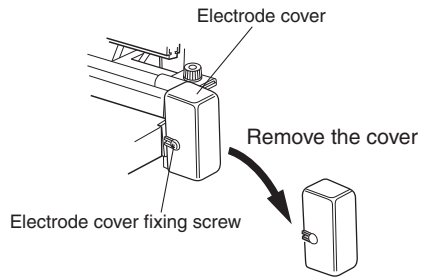

**1** Remove the teflon sheet as described in "Slide the teflon sheet".

**2** Loosen the electrode cover fixing screw and remove the cover.

**3** Raise up the electrode lever to loosen the tension of heating element.  
Then remove the heating element mounting screw by screwdriver (-).  
Old heating element can be removed.

**4** Install the new heating element and fasten the one of heating element mounting screw roughly with keeping the electrode lever raised.

Next, draw the other side heating element terminal to the electrode and fasten the mounting screw. Then tighten the temporary fastened screw.

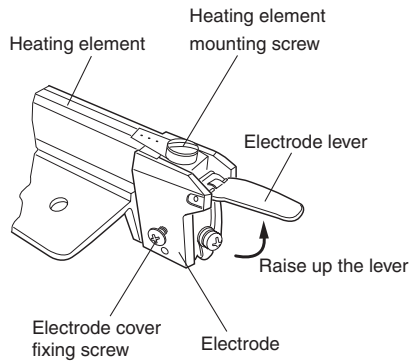

**5** Set the teflon sheet as described in "Slide the teflon sheet".

### 3 Change the glass tape, sarcon sheet

[Essential tools] Screwdriver (-)

[Replace when] The heating element has burned out.

Sealing is dirty, etc.

Glass tape and sarcon sheet is sold separately, and included in the spare parts set.

- 1 Remove the teflon sheet as described in "Slide the sheet".
- 2 Remove the heating element as described in "Change the heating element".
- 3 Peel the glass tape and sarcon sheet located below the heating element.
- 4 Attach the new sarcon sheet along the length of sealing section.
- 5 Attach the glass tape on the sarcon sheet. The glass tape must be about 5mm longer than the sealing section.
- 6 Instal the new heating element as described in "Change the heating element".
- 7 Set the teflon sheet as described in "Slide the teflon sheet".

#### TIPS

Some adhesive remain will uneven the sealing surface, and have an adverse effect.

Please clean the surface thoroughly before applying the tape and sarcon sheet.

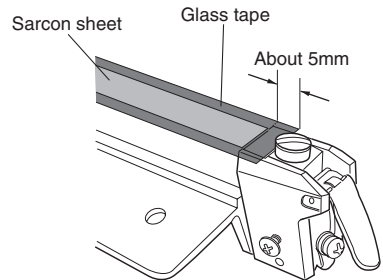
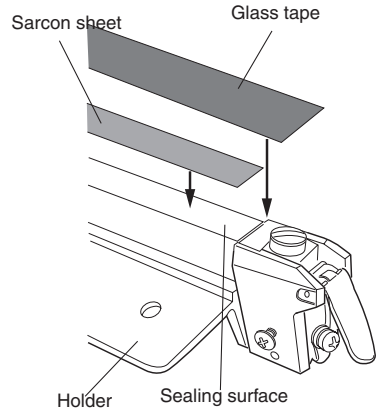

#### 4 Change the silicone rubber

[Essential tools] Phillips screwdriver (small)

[Replace when] Sealing is dirty, etc.

Silicone rubber is sold separately and included in the spare parts set.

- 1 Loosen the silicone rubber fastening screw by Phillips screwdriver (small).
- 2 Draw out the old silicone rubber from the pressure plate.
- 3 Fit the new silicone rubber's groove to the rail of pressure plate.
- 4 Fix the silicone rubber by tightening the small screw.

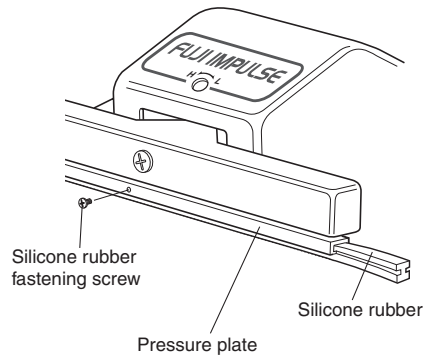

## 10 Adjust the sealing pressure

Depending on the material or thickness of the film, the proper sealing pressure may differ. Please adjust the sealing pressure at the first use or when sealing is not satisfactory.

**Warning** Always unplug the power plug from the wall outlet. It is dangerous if the microswitch turns on during adjustment.

- 1 Depress the table, and head of adjusting screw will appear in the hole of frame cover.
- 2 Sealing pressure can be adjusted by this screw.  
Insert the Phillips screwdriver through the hole.
- 3 Turn the screw counter-clockwise (H), pressure will increase.
- 4 Turn the screw clockwise (L), pressure will decrease.

**TIPS** If the adjusting screw is tightened or loosened too much, some parts will be damaged or connection of parts may be separated. Please do it carefully.

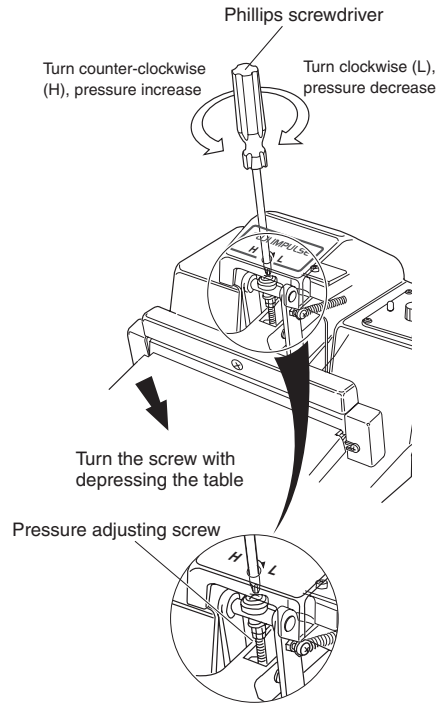

### Standard for setting the pressure

Refer to the right illustration for setting the pressure strength.

Standard opening between pressure lever and pressure plate is as follows.

