



8 Replacing routine maintenance parts

It is necessary to replace the routine maintenance parts on a regular basis. Please follow these instructions.

 **Warning** It is dangerous to try replacement without following the instructions.

 **Warning** Before replacing the routine parts, remove the power cord plug out and allow the heater section to cool. Otherwise it may cause burn or electric short.

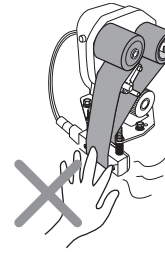

Always unplug sealer's power plug before replacing any parts.

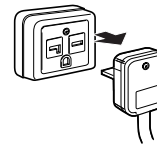

8-1 Replace the print tape

 **Warning** The heater section is very hot. Turn of the power and wait until it becomes sufficiently cool to avoid the danger of burns.

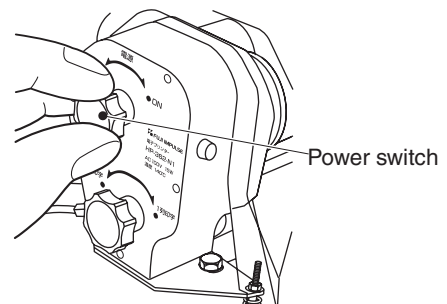

- 1 Remove the used print tape with paper core, and set the new core on the feed roller to the winding roller.

 **TIPS** Print tape paper core is attached on the winding roller at the shipment.

- 2 Push the tape adjuster to the innermost part.

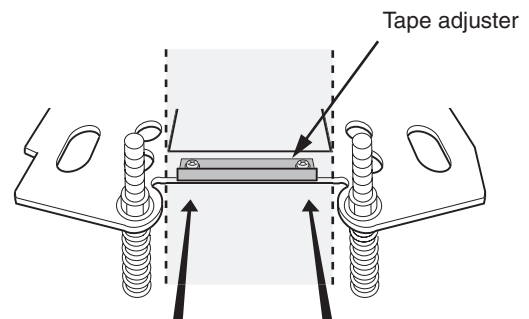

- 3 Turn the power switch counter-clockwise to turn off the power and make some space between drive roller and tape pressure roller.
- 4 Set the new print tape on the feed roller.
- 5 Thread the end of the print tape between heater section and printer base.

Set the shiny side of the print tape so that it makes contact with the type.

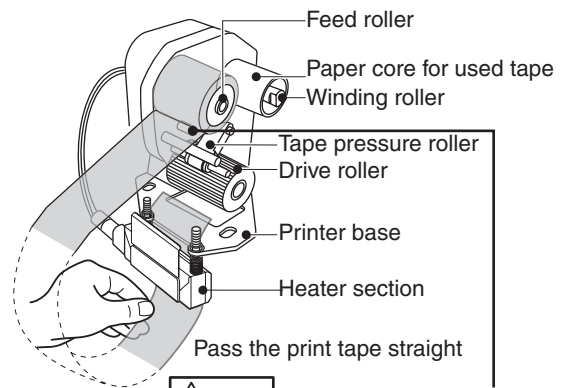

Caution Sure to set the print tape as the left illustration

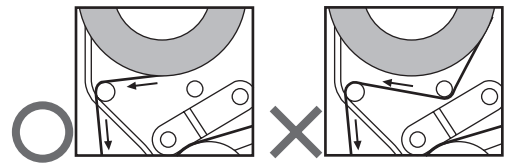

- 6 Pass the print tape straight between drive roller and tape pressure roller.
Paste the tip of print tape to the winding roller's paper core by cellophane tape.

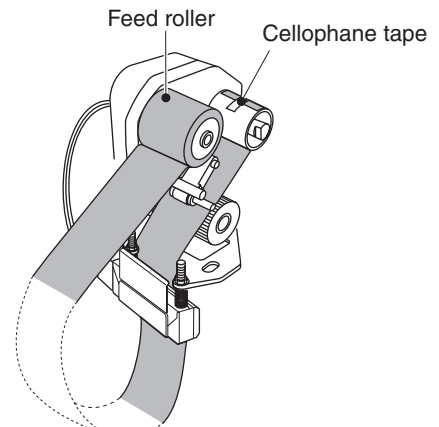

- 7 Turn the power switch clockwise.
This will both turn on the power, and fix the print tape between two rollers.

Warning After using the unit for a long time, the heater section becomes very hot.
Be careful not to burn yourself.

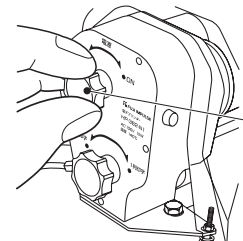

- 8 Turn the print tape to roll up the slack as the right illustration.

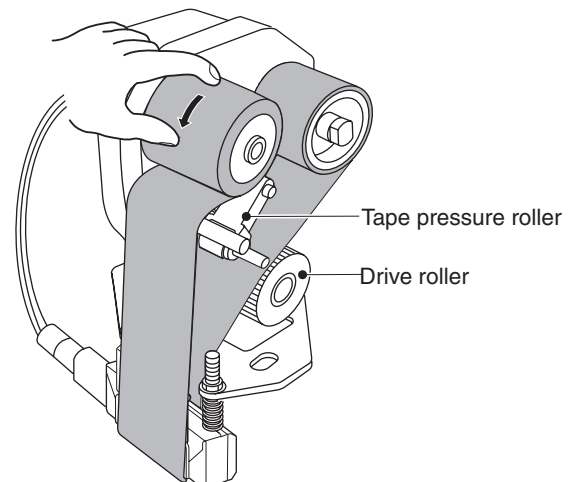

8-2 Replace the type.

[Necessary tools] Tweezers, Opener,
Type is sold separately or as a set.



The heater section and types are hot.
Replace the types after they have cooled sufficiently.

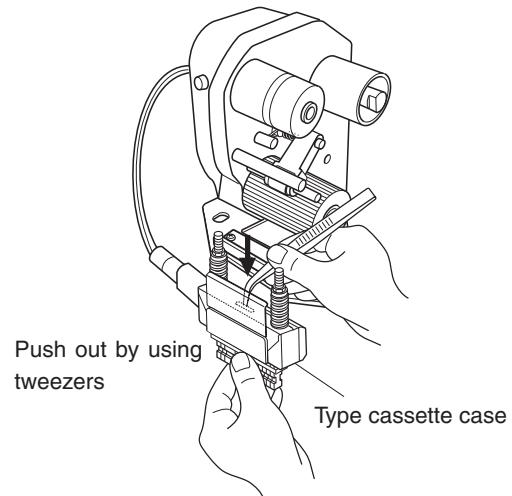

- 1 Remove the print tape cover, and take out the print tape.

- 2 Push out the type cassette case by pushing tweezers into the hole on the top of heater section.

- 3 Insert the edge of opener between the types as shown in the illustration at right. (Use the wide side of opener.)

It widens the cassette case so that types can easily be take out.

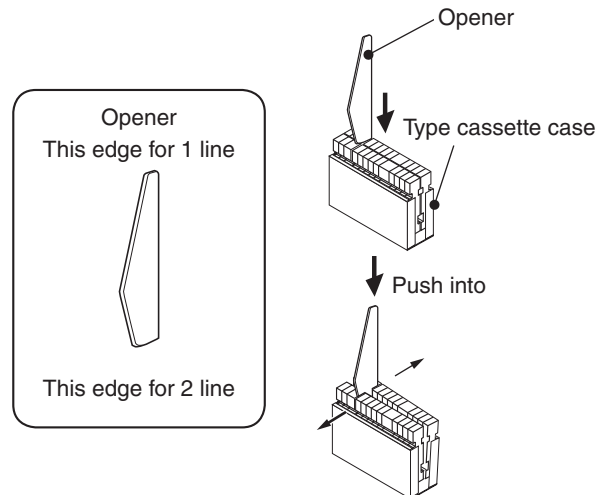

- 4 When setting the type, insert it while widening the cassette case.

Set the type so that the type's groove clicks on L-shape tip of the cassette case.

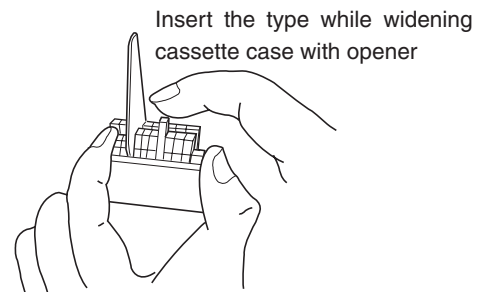

- 5 Push the cassette case back into the heater section and follow the previous instructions (page 10) to set the print tape.

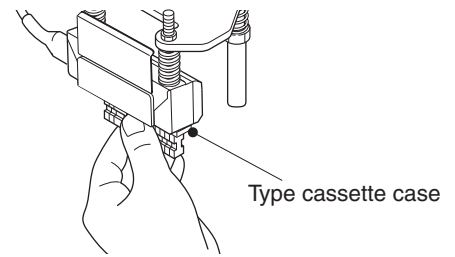

Caution When you set a few types, please put them into a center position.

If set to the right or left end, poor printing might be occurred.

Sample) When only 3 types "50g" are printed;

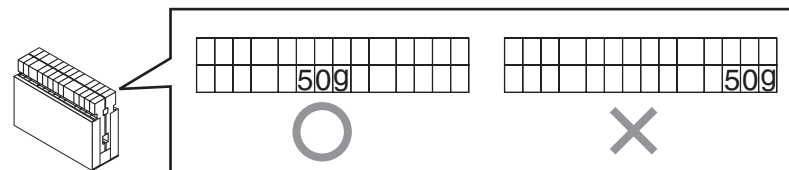

9 Adjustments

Adjustment of the part described below may need maintenance on a daily basis.
Please follow the instructions.



Do not adjust without following the instruction. It is very dangerous.



Before adjustment, pull out the power cord plug and wait until the heater section in the printer has cooled down. There is a possibility of an electrical short if you do not pull out the plug.

It may cause a burn if the heater section is not cool enough. However, to adjust the height of the heater unit, the power has to be ON in order to check the printing results. Please be careful.

9-1 Adjust the height of heater section

To insure clean printing, adjust the height of heater section according to the film material being used.

- 1 Turn the position adjusting screws clockwise to raise the heater section (types) so that, when indexing the printer downward, the printer does not print.
- 2 Turn the position adjusting screws counter-clockwise to gradually lower the type to the point where printing is visible (a little unclear). Be careful when adjusting screws (left and right) so that they are turned equally.
- 3 Turn the position adjusting screws 1/2 turn counter-clockwise to set the types in its optimal position.

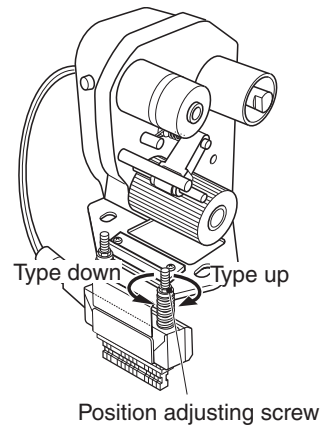

If the height of heater section is uneven at right and left, printing will not be done well.

- 1 Printing is unclear,
Turn the position adjusting screws counter-clockwise to lower the type.
- 2 Printing is too dark or printing trace is too deep.
Turn the position adjusting screws clockwise to raise the type.
- 3 Parts of the condensed type look jammed and print is too thick.
Turn the position adjusting screws clockwise to raise the type and put a glass tape on the rubber compression pad.
(Glass tape is sold separately.)

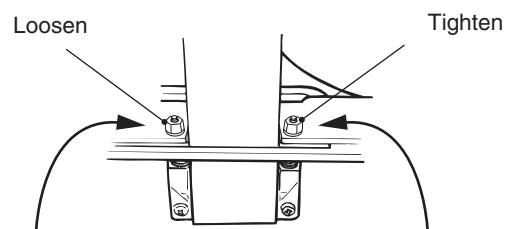

When printing is light EXP. DATE 00. DEC.12 When printing is dark
PRO. DATE 00. SEP.12

9-2 Adjust the number of printer lines.

The number of printing lines can be selected by selector switch.

It changes the length of tape feeding and to save the print tape.

Initial state (at the shipment) is for two lines.

If dialed to the 1 line, the tape feed length changes to for 1 line (about 5mm).

If you set the 36mm spacer, 1 line becomes blank and 1 line printing can be done.

TIPS Must set the 36mm spacer into un-used side of cassette case when 1 line printing.

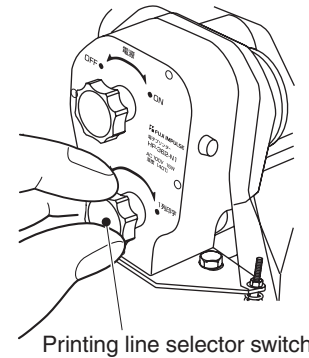

9-3 Adjust the length of tape feed.

The length of tape feed is set as follows at the shipment.

2 line printing ... 10mm

1 line printing ... 5mm

To increase or decrease the tape feed length, turn the actuator pin adjustment as shown in the right illustration.

Caution When the printer is shipped, the tape feed quantity is adjusted properly.

Do not change this unless necessary.

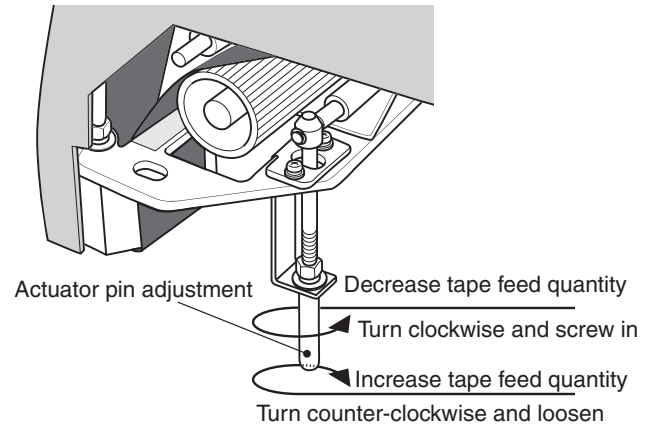

9-4 Adjust the slack of print tape

Sometimes the print tape would be slid a little from the printing position as it is wound up. In this case, please control the tape adjuster

- 1 When the print tape is slid to the right side.
Loosen the screw and pull the right side of tape **adjuster**.
- 2 When the print tape is slid to the left side.
Loosen the screw and pull the left side of tape adjuster.

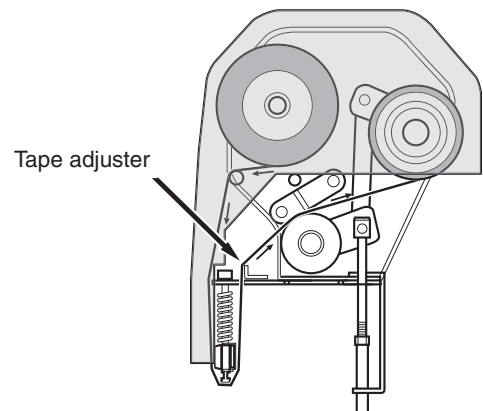
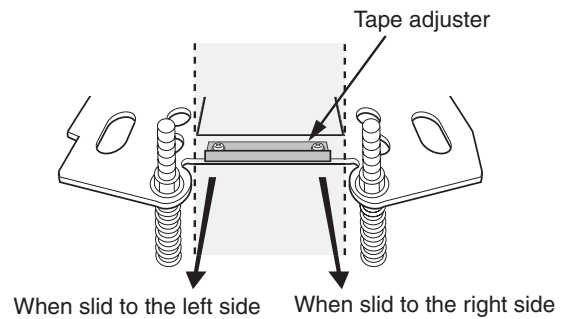

* Fasten the screw keeping the tension of tape.