

9 Replacing the routine maintenance parts

Daily maintenance or replacement of parts at an early stage can prevent the machine from being damaged, and keeps the machine at the optimum condition. Replace parts according to the following directions in order to maintain your machine in optimum operating condition.



Warning Always unplug the power plug before replacing parts. There is a danger of electrocution if it has been done without unplugging.



Warning Follow the directions on this manual when replacing parts. Replacing parts in the way ignoring this manual could cause malfunction of the machine as well as electrocution and fire.



Warning Always use only specified parts sold through Fuji Impulse. Unspecified parts may cause malfunction of the machine.



Always unplug the machine before maintenance.

Structure of the sealing section

The sealing section consists of the parts as in the illustration below. When replacing parts, be careful to arrange the parts exactly in the same order.

Single side heating

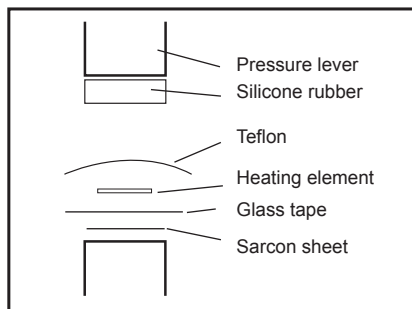

Double side heating

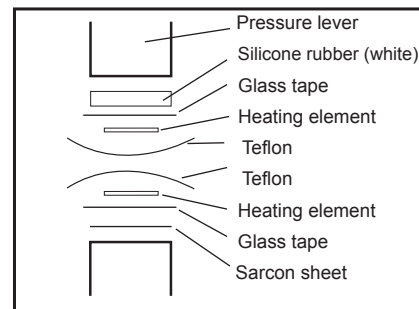

9-1 Preparation

•Before replacing parts

When replacing parts, lift up the pressure lever for easier replacement.

How to lift up the pressure lever

Turn the pressure adjusting nut at the center of the pressure lever fully counterclockwise, and remove the pressure adjusting nut. Lift up the pressure lever. For the installment method, please refer to “10-1 Adjusting the sealing pressure >>> **Attention!**”



Warning When the pressure lever is lifted up, you can activate the microswitch by clicking it with a thin stick, etc. Do not activate the microswitch as it will start heating and may result in fire if the plug is not unplugged. Please refer to warning of “9-7 Replacing the microswitch.”

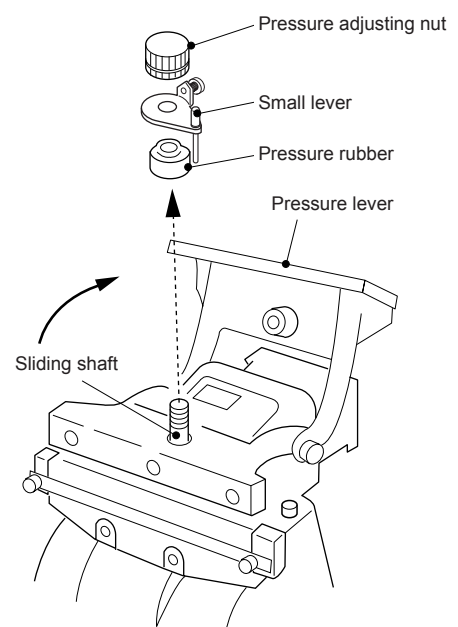

9-2 Sliding the Teflon sheet

Essential tools: Scissors, a Philips screwdriver

Replace when: The Teflon burns, or when the seal becomes messy.

Teflon is either sold individually or included in the maintenance parts kit. It is rolled to the Teflon roll bar about 25 - 30cm as an extra.

□ Lower Teflon sheet

- 1 Loosen two black plastic nuts at the front side of the machine to remove the lower Teflon sheet holding plate.
- 2 Loosen two black plastic nuts that fix the Teflon roll bar fastening plates so the Teflon roll bar can be moved, and slide the Teflon toward you.
- 3 Cut the damaged part of the Teflon with scissors.
- 4 Insert the edge of the Teflon between the lower Teflon holding plate and Teflon sheet holder support. And then fix the lower Teflon sheet holding plate with black plastic nuts.
- 5 Roll up the Teflon to the Teflon roll bar so it does not get wrinkled.
- 6 Tighten the black plastic nuts to secure the Teflon roll bar with Teflon roll bar fastening plates.

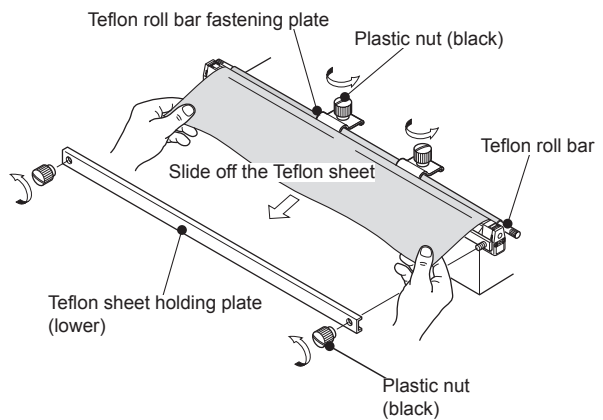

□ Upper Teflon sheet

(For FA-200, FA-300 double side heating type)

- 1 Loosen the screws that fix the upper Teflon sheet holding plate and slid off the edge of the Teflon.
- 2 Loosen the screws of the Teflon sheet holding brackets so the Teflon roll bar can be moved. Slide the Teflon toward you.
- 3 Cut the damaged part of the Teflon with scissors.
- 4 Insert the edge of the Teflon between the upper Teflon sheet holding plate and pressure lever and tighten the screw loosened at procedure 1 to fix the Teflon edge.
- 5 Roll up the Teflon to the Teflon roll bar so it does not wrinkle.
- 6 Tighten the screws of the Teflon sheet holding brackets to secure the Teflon roll bar.

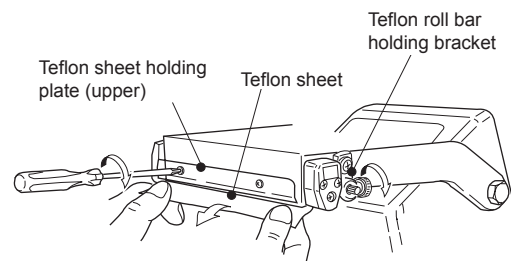

- Upper Teflon sheet
(For FA-450, FA-600 double side heating type)

- 1 Loosen the white plastic nuts at the backside of pressure lever so the Teflon roll bar can be moved.
- 2 Loosen the screws that fixes the upper Teflon sheet holding plate and slide off the Teflon to the direction of allow.
- 3 Cut the damaged part of the Teflon with scissors.
- 4 Insert the edge of Teflon between the upper Teflon sheet holding plate and pressure lever, and tighten the screws to fix the Teflon sheet holding plate.
- 5 Roll up the Teflon to the Teflon roll bar so it does not wrinkled.
- 6 Tighten the white plastic nuts to secure the Teflon roll bar with upper Teflon roll bar fastening plates.

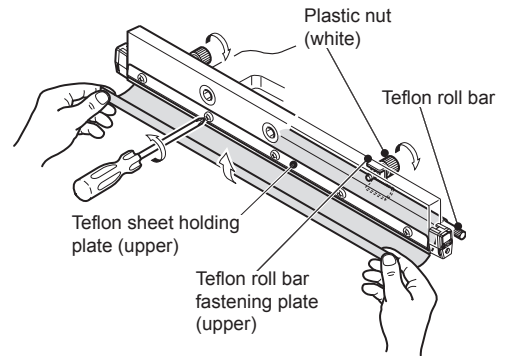

9-3 Replacing the heating element

Electrodes that mount the heating element consist of parts as in the right illustration.

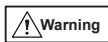

If you loose the screw C, do not substitute ones longer than the screw C (M4x6) as there is a danger of short circuit by the longer screw touching screw D.



When replacing the heating element, replace the glass tape and Sarcon sheet as well if they appear to be damaged. If they are damaged and cannot properly insulate the heating element from the body frame, the short circuit may result.

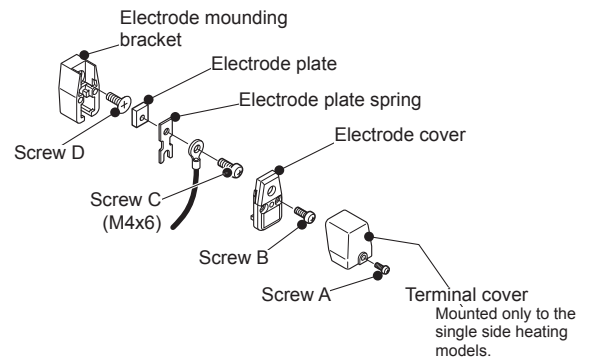

Essential tools: A Philips screwdriver

Replace when: The heating element breaks, unevenness is generated, or when the seal becoms messy.

The heating element is either sold individually or included in the maintenance parts kit.



The heating element can be replaced without removing the electrode cover so you will not loose the cover or screw.

□ Lower heating element (for all models)

- 1 Remove the Teflon sheet. (Refer to “9-2 Sliding the Teflon sheet.”)
- 2 Loosen the screw A of both electrodes with a Philips screwdriver, and remove the terminal covers. The illustration on the right describes the electrode after the terminal cover is removed.
- 3 Loosen screw B of both electrodes to loosen the tension of the heating element. It is not necessary to remove the electrode covers.
- 4 Insert a Philips screwdriver into the hole of the electrode cover and loosen screw C. The heating element can be removed.
- 5 When mounting the new heating element, insert each terminal between the electrode plate and electrode plate spring. While pushing down the terminal with your fingers so it stays in place, tighten the screw C with a Philips screwdriver.
- 6 Tighten the screw B loosened at the procedure 3 so the heating element is stretched tight. When the screw B is not tightened enough, the heating element will not be stretched tight enough, which may result in damaging the heating element.
- 7 Fix the terminal covers to the electrodes with screw A.

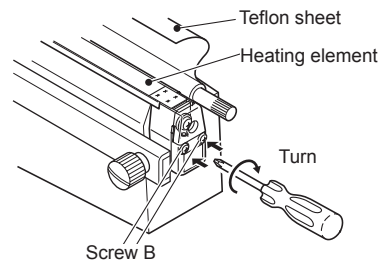

Without loosening the screw B, the heating element will be kept stretched tight. Thus the heating element terminal cannot be inserted between the electrode plate and plate spring.

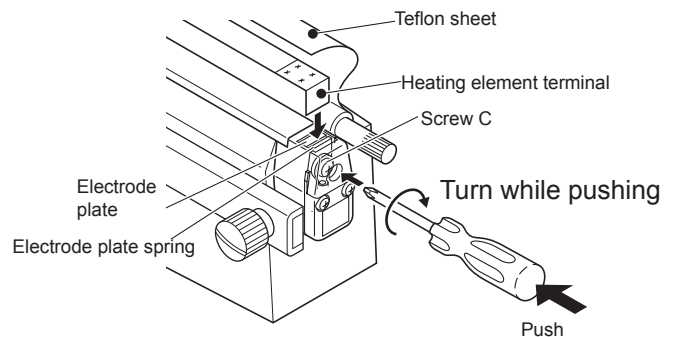

□ Upper heating element (for double side heating models)

- 1 Remove the Teflon sheet. (Refer to “9-2 Sliding the Teflon sheet.”)
- 2 Loosen the screw B of both electrodes with a Philips screwdriver, and remove the terminal covers. The illustration on the right describes the electrode after the terminal cover is removed.
- 3 Insert a Philips screwdriver into the hole of the electrode cover and loosen screw C. The heating element can be removed.
- 4 When mounting a new heating element, insert each terminal between the electrode plate and electrode plate spring. While pushing down the terminal with your fingers so it stays in place, tighten screw C with a Philips screwdriver.
- 5 Tighten the screw B loosened at the procedure 2 so the heating element is stretched tight. When the screw B is not tightened enough, the heating element will not be stretched tight enough, which may result in damaging the heating element.

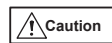
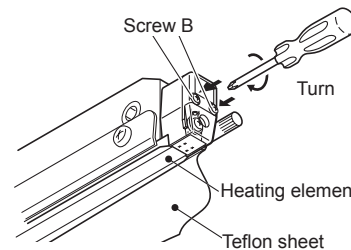

Without loosening the screw B, the heating element will be kept stretched tight. Thus the heating element terminal cannot be inserted between the electrode plate and plate spring.

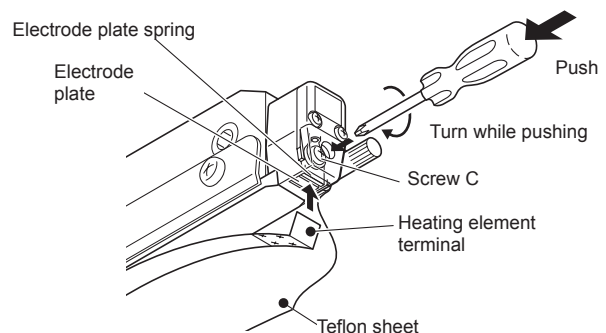

9-4 Replacing the glass tape and Sarcon sheet

Essential tools: Scissors, A Philips screwdriver

Replace when: The heating element breaks often, the seal becomes messy, etc.

The glass tape and Sarcon sheet are either sold individually or included in the maintenance parts kit.

- 1 Carefully read the respective replacement instructions on the Teflon and heating element and remove all of them.
- 2 Completely remove the glass tape and Sarcon sheet.

Attention! Applying the Sarcon sheet and glass tape to a surface with adhesive residues will negatively affect the sealing surface.

- 3 Cut the new Sarcon sheet 2mm longer than the seal area for left and right sides and adhere it to the lever.
- 4 Adhere the glass tape over the Sarcon sheet so it covers the electrode about 5mm.

Attention! If the adhesive of the Sarcon sheet is weak when replacing the glass tape, please replace the Sarcon sheet as well.

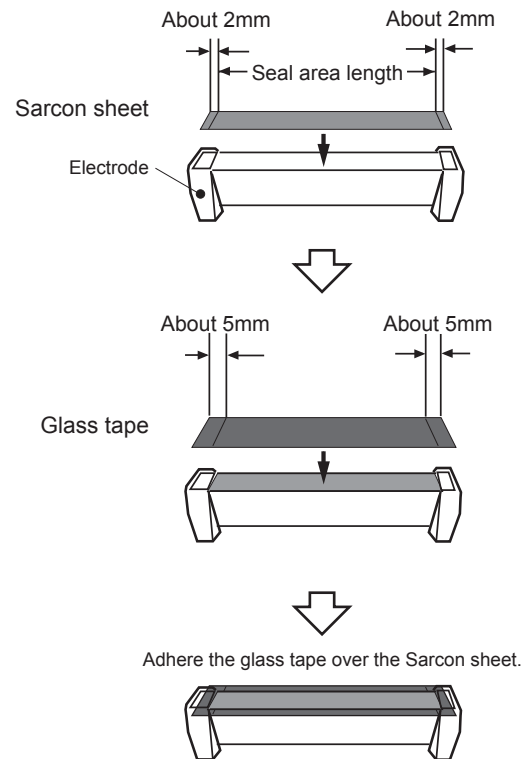

9-5 Replacing the silicone rubber

Essential tools: Industrial-purpose alcohol (Ethanol)

Replace when: The seal becomes messy, etc.

The silicone rubber is either sold individually or included in the maintenance parts kit.

- 1 Remove the damaged (old) silicone rubber.
- 2 Using an industrial purpose alcohol, etc., completely remove the adhesive residues remaining on the metal portion of the pressure lever.
- 3 Adhere the new silicone rubber starting from the edge.

Attention! Adhere the silicone rubber carefully as it cannot be reapplied.

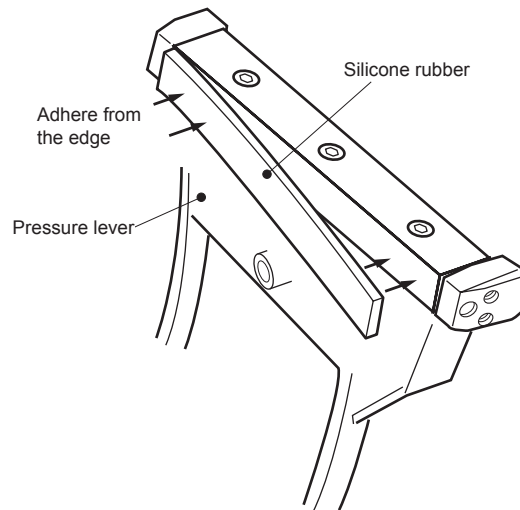

9-6 Replacing the pressure rubber

Essential tools: N/A

Replace when: The height of the shock absorbing clearance become lower than 2mm. (New pressure rubber has 3mm in height.)

The pressure rubber is sold individually.

Please inspect the height of shock absorbing clearance periodically.

Lift up the pressure lever referring to “9-1 Preparation” for the easier replacement.

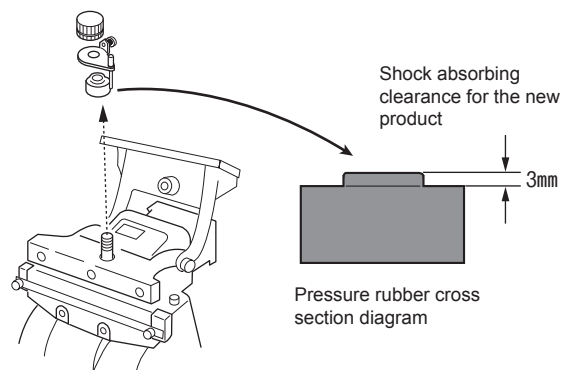

Warning New pressure rubber has 3mm-high shock absorbing clearance. The long-term use of the machine could cause the wear-out of the pressure rubber. If the shock absorbing clearance become lower than 2mm, sealing pressure increases and too much pressure can be applied to the sealing area. This is extremely dangerous especially when a finger is caught in the sealing area by any chance.

Inspect the pressure rubber before the operation and replace it if necessary.

9-7 Replacing the microswitch

Essential tools: A Philips screwdriver

The microswitch is sold individually.

 **Warning** Always unplug the power cord from the outlet when replacing the microswitch.

- 1 Referring to “9 Replacing the routine maintenance parts >>> 9-1 Preparation,” lift up the pressure lever.
- 2 Loosen the screws that fix the microswitch case to the common frame, and remove the microswitch case.
- 3 Next, loosen the screws that fix the microswitch, and remove it from the microswitch case.
- 4 Remove all of the cables.

Installation

- 5 When reattaching the microswitch, wire properly referring to “12 Electric diagram.” If the wiring is not correct, the timer may be damaged.

 **Warning** If the wiring of the microswitch is not correct, the timer may be damaged. Regarding the triac connection, the label is adhered to the timer.

- 6 Attach the microswitch to the microswitch case removed at the procedure 3 using the screws. Please refer to the illustration on the right for how to install to the microswitch case.
- 7 Attach the microswitch case to the common frame.
- 8 Return the pressure lever etc. removed at the procedure 1 to the initial state.

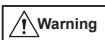
 **Warning** If you activate the microswitch by pushing it with a thin object, it may bring the heat to the heating element and there is a danger of burning or fire.

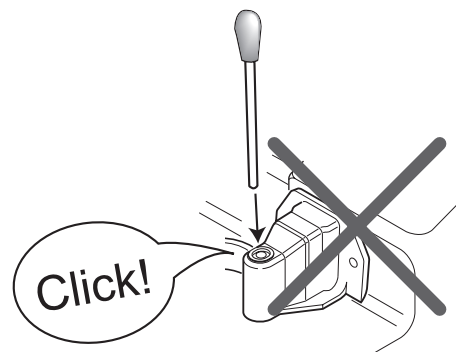
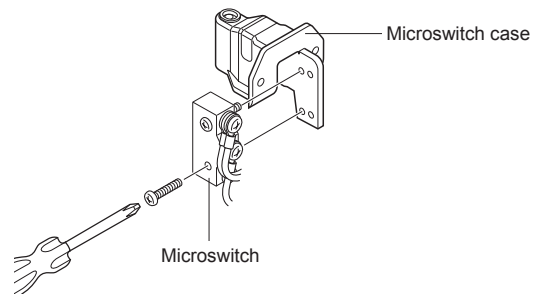
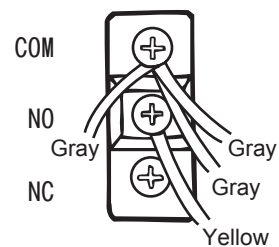
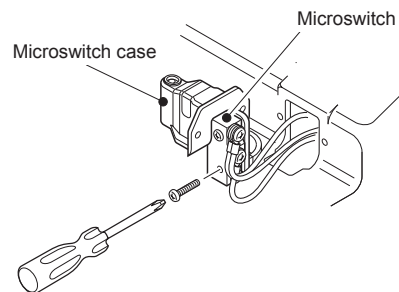
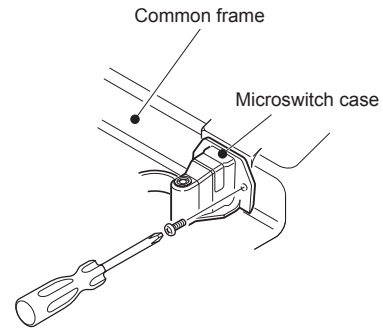

10 Adjusting each part

10-1 Adjusting the seal pressure

Adjust the pressure strength indicated on the seal pressure adjusting nut using the pointer on the small lever.

- 1 Loosen the pressure adjusting nut fastening screw.
- 2 Turn the pressure adjusting nut to adjust the sealing pressure to a level suited for the thickness of the packaging material used. Use the compatible thickness described on the pressure adjusting nut as guidance. (Turn the pressure adjusting nut fully clockwise as it stops at the pressure for less than 0.1mm, then turn counterclockwise to adjust.)
- 3 Once the adjustment is made, always use the securing screw to secure the pressure adjusting nut.

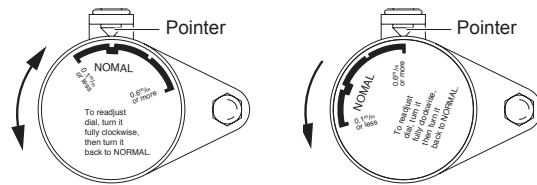
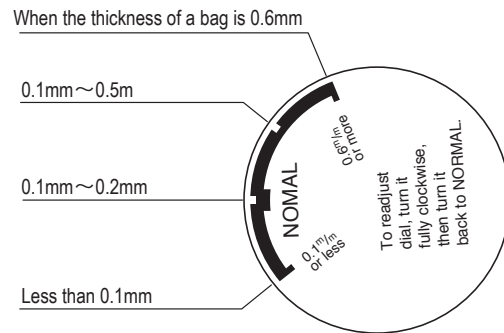
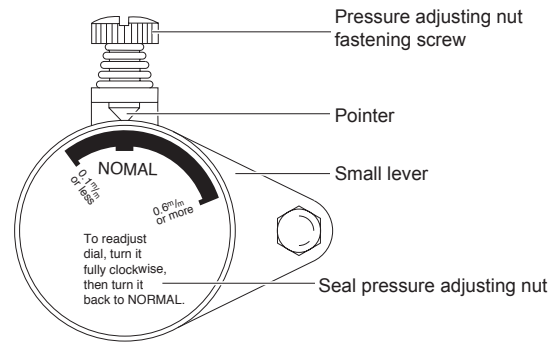

Warning Operating while the nut is turned excessively clockwise (the direction for handling thinner packaging material) may cause sealing failure or cause the pressure lever to remain at the lowered position due to the solenoid suction strength dropping and the microswitch not being activated. In addition, it is very dangerous due to the excessive pressure. Always operate by following the instructions in the following **Attention!** and the setting within the red range described on the label on the adjusting nut.



Warning Operating while the nut is turned excessively counterclockwise (the direction for handling thicker packaging material) will increase the sound of the pressure lever movement.



Attention! What to do if you loosen the pressure adjusting nut too much. In the case you have loosened and caused to remove the pressure adjusting nut at the time of parts replacement:

Turn the pressure adjusting nut fully clockwise so that it stops at [Less than 0.1mm] scale. Then adjust the pointer on the scale for the packaging material. Normally, operation is done in the [NORMAL] position.

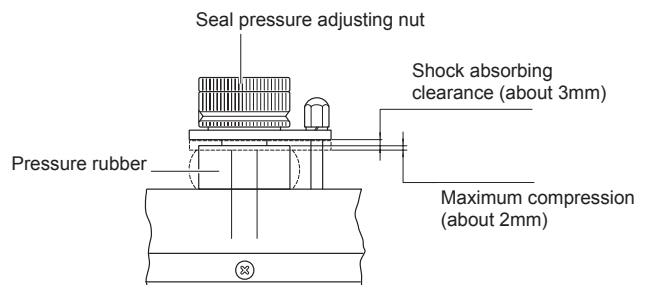

10-2 Table switch plate actuator pressure adjustment

When the bag contents are heavy, the table switch may be turned on immediately and activate the sealer. Adjust the table pressure adjustment screw so the table does not activate the sealer.

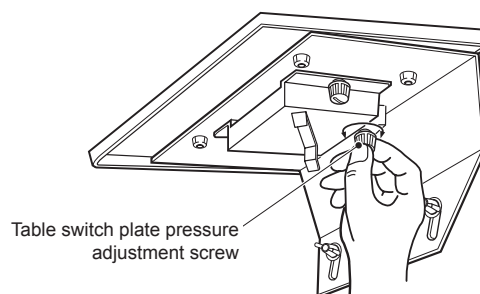

The pressure adjusting spring is installed inside the screw.