

## 8 Proper use of the sealer

Use only as described in this manual.

There is a risk of danger and malfunctions may result if the machine is used not in accordance with this manual.

### 8-1 Setting the machine

FA series is the table-top type sealer. Place the machine on a flat, horizontal working table.

The optional FA stand is available when you cannot secure the proper working place.

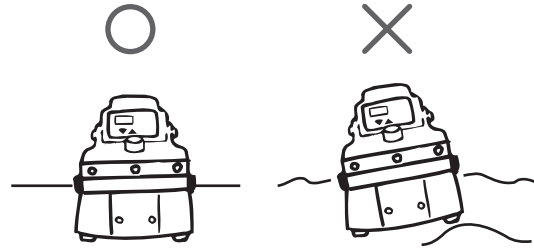

### 8-2 Mounting the table

#### A Mount the table-switch plate

Skip this procedure when using the air pedal as a foot switch.

##### 1 FA-200, FA-300 Series

Fix the table-switch plate to the body frame using the wing nut. The height can be adjusted to the optimum level depending on the application. (The wing nut is installed to the bolt of the body frame where the table is installed.)

##### 2 FA-450, FA-600 Series

The table-switch plate cannot be mounted to these sealer models. (Refer to "8-6 Select the operation mode >>> How to set each operation mode.")

#### A Table-switch plate

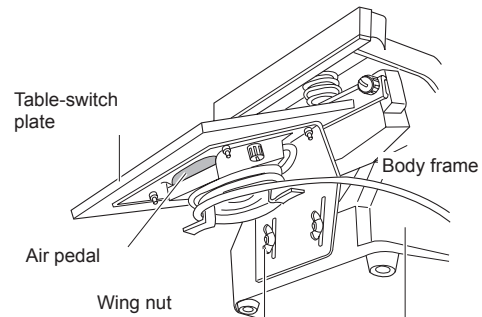

#### B Mount the standard table

For the FA series of sealers, the standard table will be optional parts except for FA-450-5.

Fix to the seal frame using the wing nuts and bolts. The height can be adjusted to the optimum level depending on the application.

#### B Standard table

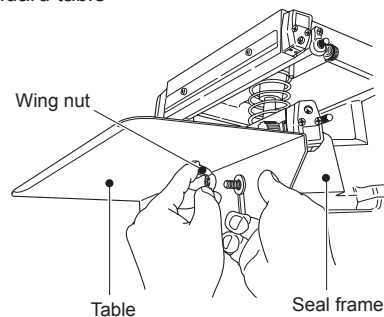

### C Mount the special table (Optional)

The special table can be mounted to the FA stand, which is sold individually. (The air pedal cannot be installed to the special table.)

### C Special table

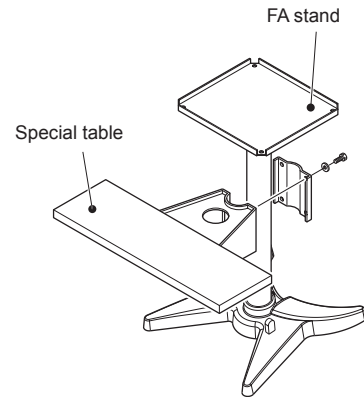

## 8-3 Insert the air hose

Insert the air pedal hose securely into the elbow of the main frame air switch.

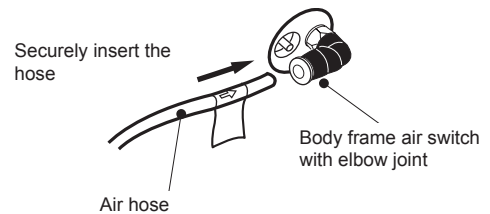

## 8-4 Plugging in the electrical power cord.

The power cord is located on the right side of the machine, when facing toward it. Make sure the electrical outlet has adequate current carrying capacity as described at "1. Specification." Insert the electric power plug fully into the wall outlet.



There is a danger of fire if the electrical power source does not meet proper specification.

## 8-5 Power switch ON

The control unit display will turn on when the power switch, located on the side of the common frame, is pushed on.



Push to turn ON

## 8-6 Select the operation mode

The "Auto cycle START/STOP" button allows you to select between manual and continuous automatic operation.

Turn ON or OFF the auto-cycle interval mode after selecting the operation mode referring to "8-7 Setting the sealing condition."

For the detail, refer to "8-6 Select the operation mode >>> How to set each operation mode."

- Auto-cycle interval mode OFF  
(Auto cycle interval lamp OFF)

- 1 Air pedal operation ..... The machine operates when the air pedal is depressed.
- 2 Table switch plate operation ..... The machine operates when the table switch plate is pushed.

1 Air pedal operation

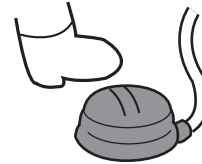

2 Table-switch operation

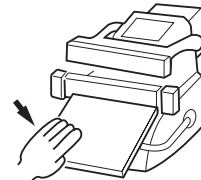

- Auto-cycle interval mode ON  
(Auto cycle interval lamp ON)

- 3 Auto cycle mode ..... Automatic operation takes place based on the preset intervals.

3 Auto-cycle mode

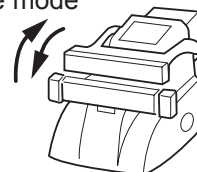

How to set each operation mode

Operation mode	FA-200, FA-300 series	FA-450, FA-600 series
Air pedal operation	Push the Auto Cycle START/STOP button to turn OFF the auto cycle mode. Remove the air pedal set to the table-switch plate. Place the air pedal on the floor or the other place.	Push the Auto Cycle START/STOP button to turn OFF the auto cycle mode. Set the air pedal included in the accessories referring to "8-3 Insert the air hose".
Table-switch plate operation	Push the Auto Cycle START/STOP button to turn OFF the auto cycle mode. Mount the table-switch plate referring to "8-2 Mount the table".	Table-switch plate operation cannot be selected.
Auto-cycle mode	Set the auto-cycle interval time. Turn ON the auto-cycle mode by pushing the Auto Cycle START/STOP button.	

### 8-7 Setting the sealing condition with the control unit

The heating time, cooling time and auto-cycle interval can be set with the control unit.

The setting values will vary depending on the pouch/film material, thickness, etc. Reset the seal conditions every time you change the bag.

Pushing the SET button changes the modes in the following order:

COUNTER→HEATING TIME→COOLING TIME→AUTO CYCLE INTERVAL.

The mode indicator lights show which mode is currently displayed. If no light is lit, the machine is in the counter mode.

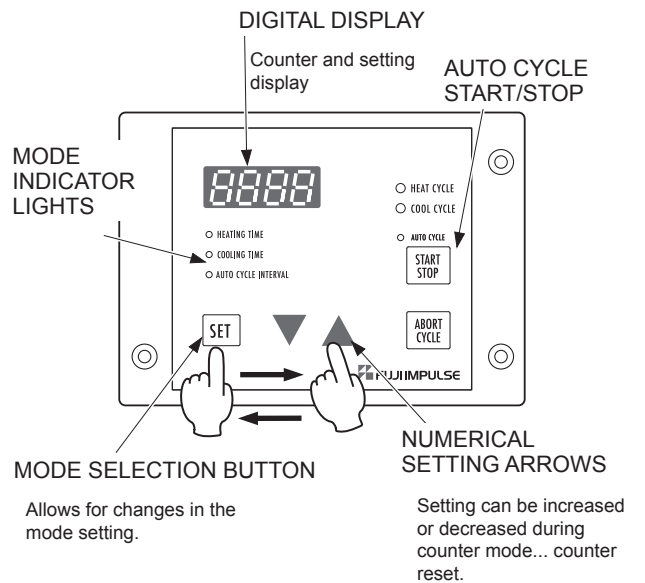

Setting the heating time

- Activate the "heating time" mode. Use ▲/▼ arrows to set the heating time. [Setting range : 0.1 - 1.6 sec. ]
- The optimum heating time will differ depending on the voltage when the machine is used, the thickness and type of film.
- Set the heating time at minimum to make a sufficient seal. This will increase the productivity and also prevent unnecessary power consumption.

Setting the cooling time

- Activate the "cooling time" mode. Use ▲/▼ arrows to set the cooling time. [Setting range : (set heating time) - 5.0 sec.]
- The cooling time should be set 1.5 to 2 times longer than the heating time. In order to guarantee sufficient cooling time, the FA series is designed that the cooling time cannot be set shorter than the set heating time.
- When setting the heating time, the control unit will automatically correct the cooling time to the same amount as the set heating time if the heating time is set longer than the cooling time.

Setting the auto-cycle interval

- Activate the "auto-cycle interval" mode. Use ▲/▼ arrows to set the interval. [Setting range : (set heating time x 3 times) - 5.0 sec.]
- The interval time for the auto-cycle interval mode is set 3 times longer than the heating time, and cannot be set shorter than that.  
When the heating time is made longer, the control unit will automatically adjust the auto-cycle interval time if it is shorter than 3 x heating time.

## Setting the different modes

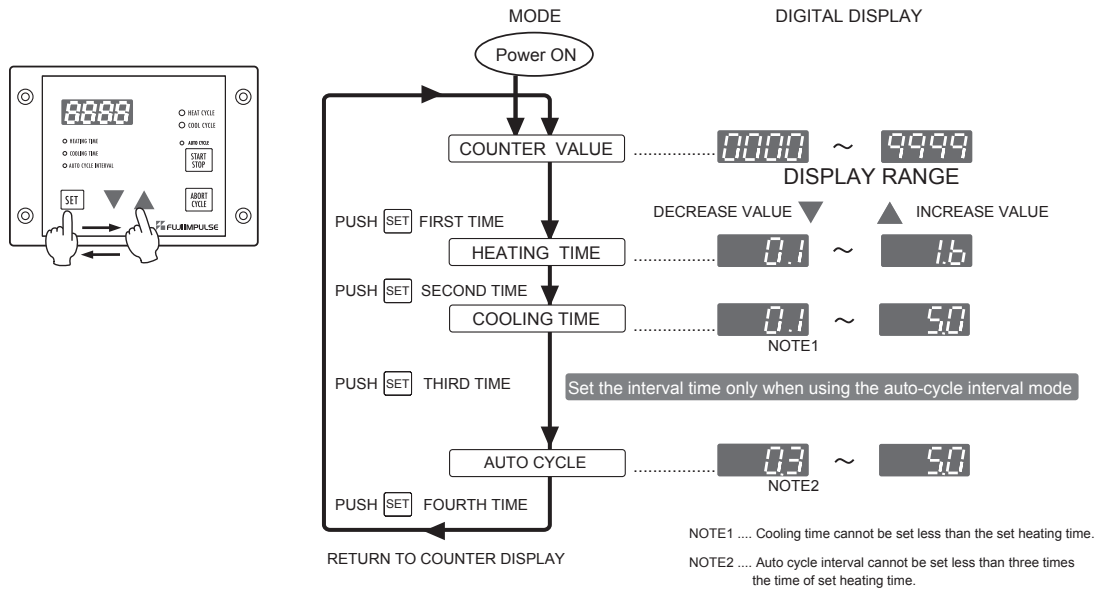

## Example)

Settings : Heating 0.8 sec. Cooling 1.2 sec. Auto cycle 2.4 sec.

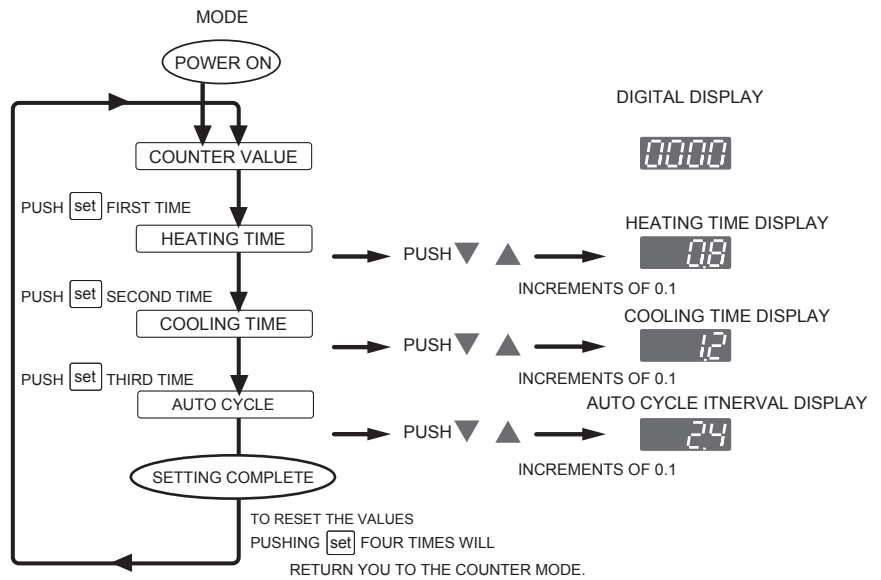

## 8-8 Adjust the seal pressure

The pressure adjusting nut is adjusted to the "NORMAL" position for the film of 0.1 to 0.2 mm thickness at the time of factory shipment.

The required sealing pressure varies depending on the type and thickness of the film. Adjust the sealing pressure according to each of the film to be used.

**Attention!**

Perform the pressure adjustment referring to "10-1 Adjusting the sealing pressure." Change the pressure setting every time you change the film.

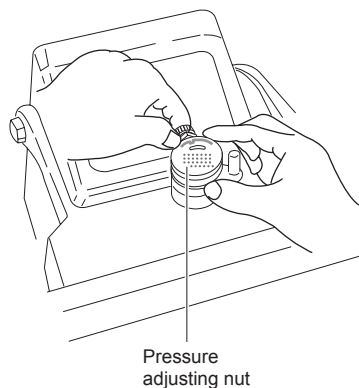

## 8-9 Perform test sealing

After completing the control unit and seal pressure adjustment, turn off the auto-cycle mode and manually perform the seal test to find the optimum sealing condition for your film.

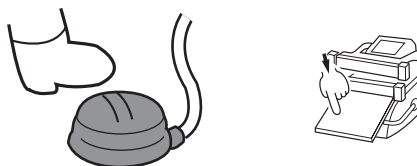

## 8-10 Seal with the selected operation mode



The sealing area become hot with the prolonged use, and there is a danger of burning.

Also, it is extremely dangerous to place fingers to the sealing area where the strong pressure is applied. The machine is designed to release the pressure when the microswitch is not activated within 0.8 seconds due to the foreign objects being inserted to the sealing area. However, the strong pressure is applied especially to both ends of the sealing jaws. Please be careful as the sealer may start heating. (Especially for FA-450 and 600 series.)

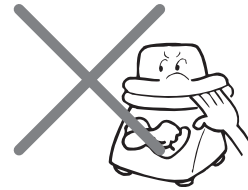

### 1 Air pedal operation

Place a pouch to the sealing area. Depressing the air pedal will lower the pressure lever to start sealing.

### 1 Air pedal operation

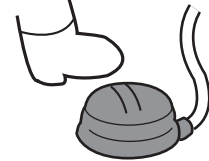

### 2 Table-switch plate operation

Place a pouch to the sealing area. Lightly press the part of the table-switch plate where indicated by the label to lower the pressure lever and start sealing.

### 2 Table-switch plate operation

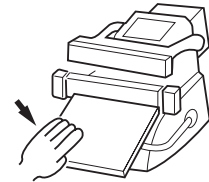

### 3 Auto-cycle interval mode

Automatic operation takes place based on the preset intervals. Place a pouch to the sealing area according to the timing that the pressure lever descends. You can deactivate the auto-cycle mode by pushing the Auto-Cycle START/STOP button.

### 3 Auto-cycle mode

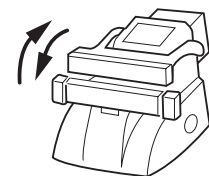

- **ABORT CYCLE button**

To stop the operation after the machine started working, push the “ABORT CYCLE” button. The lever will return to the initial position. The set value will not be erased even if the “ABORT CYCLE” button is pressed.

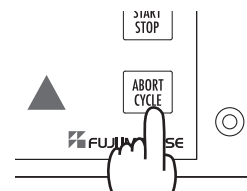

### 8-11 Finishing sealing

After the heating and cooling cycle has finished, the pressure lever returns to the initial position, and the sealing is complete. If a sealing is not clean enough, adjust the heating/ cooling time or sealing pressure.

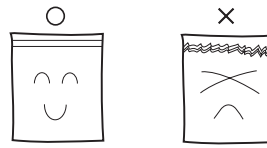

### 8-12 Counter reset

As the sealing operation proceeds, the numeric value of the counter increases one at a time from 0000 to 9999.

When you want to reset the counter to 0000, push either ▲ or ▼ arrow buttons while the machine is in the counter mode.

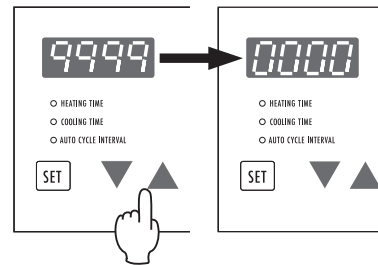

### 8-13 Power switch OFF

After finishing operation, always turn OFF the power switch.



Push to turn OFF

As the set value and the seal count are retained by the control unit, there is no need to put the value every time after turning OFF the power switch.

Unplug the power outlet in the case of not using the machine for a while.

### 8-14 Inspection after operation

After use, please clean up the parts. Inspect parts such as Teflon and heating element to make sure that they are not damaged. If the parts appear to be damaged, replace them referring to operating instruction.