

9 Replacing the routine maintenance parts

Replace parts according to the following directions in order to maintain your machine in optimum operating condition.



Always unplug the power plug before replacing parts. There is a danger of electrocution if it has been done without unplugging.



Follow the directions on this manual when replacing parts. Replacing parts in the way ignoring this manual could cause malfunction of the machine as well as electrocution and fire.



Always use only specified parts sold through Fuji Impulse. Unspecified parts may cause malfunction of the machine.



Always unplug the machine before maintenance.

Construction of the sealing area

The sealing area is constructed with parts illustrated in the diagram at left. When replacing parts, be careful to arrange the parts in the same exact order.

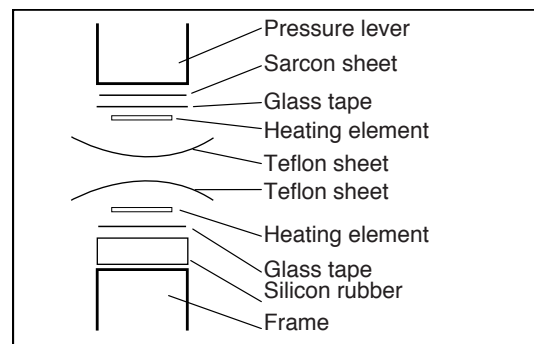

9-1 Preparation

Raise the pressure lever to ease the task of replacing parts.

- 1 Pull out U-shaped washer from between the pressure adjustment nut on the tip of the pulling rod and pressure lever by pushing down the pressure lever. Repeat this action when re-attaching the U-shaped washer.

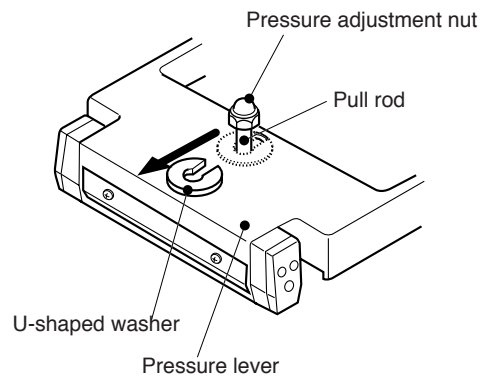

If the machine is operated with the U-shaped washer misaligned, undue pressure will be exerted on the pressure lever and damage may result. Set the washer securely into the groove.

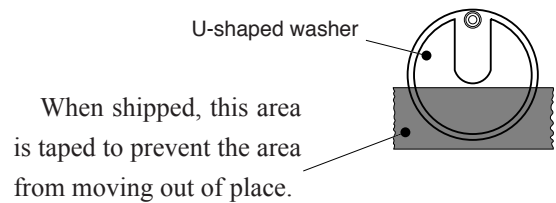

- 2 The pressure lever can be raised once the pressure adjustment nut is passed through the hole in its top.

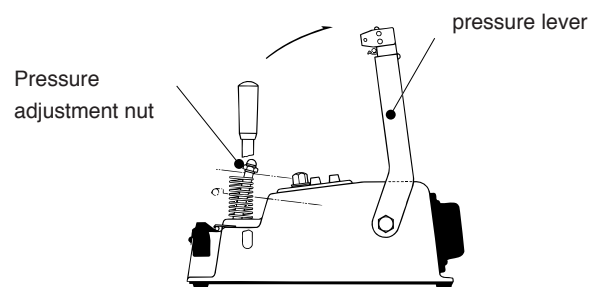

9-2 Sliding the Teflon sheet (on the upper side)

Essential tools: Scissors, Philips screwdriver

Replace when: The Teflon breaks, burns or when the seal becomes messy.

The extra Teflon sheet is rolled up to the winding rod about 25-30cm.

1. Loosen the screws of the Teflon holding plate and the screws on top of the pressure lever.
2. Pull out new sheet of Teflon over the heating element by pulling the ends of the Teflon.
3. Cut off excess with scissors.
4. When inserting, place ends of Teflon sheet between Teflon holding plate (upper) and pressure lever. Secure Teflon holding plate with screws.
5. Straighten out Teflon sheet by turning Teflon winding rod.
6. Stabilize Teflon winding rod by securing the screws on top of the pressure lever.

TIPS

Secure Teflon winding rod by holding Teflon winding rod holder (upper) while securing screws on top of the pressure lever (Refer to "9-3 Upper Teflon sheet replacement").

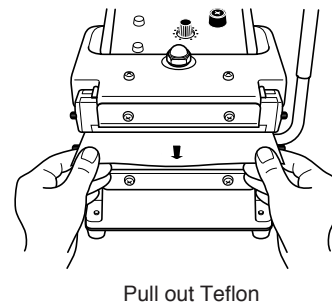
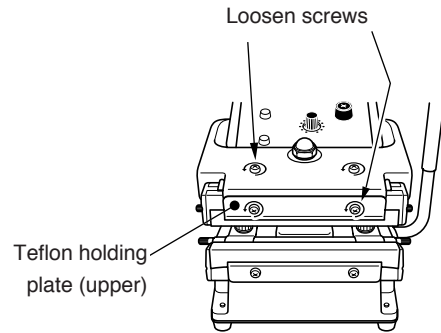

9-3 Upper Teflon sheet replacement

Essential tools: Scissors, screwdriver (Philips)

Replace when: The Teflon breaks, burns or when the seal becomes messy.

Teflon sheet is sold individually or included in the maintenance parts kit. The extra Teflon sheet is rolled up to the winding rod about 25-30cm.

Attach the new Teflon sheet when all part of the Teflon sheet is used. When doing so, please be careful not to rip the Teflon sheet with the upper Teflon holding plate.

1. Lift up the pressure lever referring to "9-1 Preparation."
2. Loosen the screws at the pressure lever to loosen the Teflon winding rod holder on the back side of the pressure lever. Now the Teflon winding rod is loosened.
3. Slide off the Teflon winding rod from the side.
4. When installing the Teflon and winding rod, insert them from the side.
5. While holding the Teflon winding rod holder (upper) with your fingers to prevent it from rolling, tighten the screws at the pressure lever to fix the Teflon winding rod.

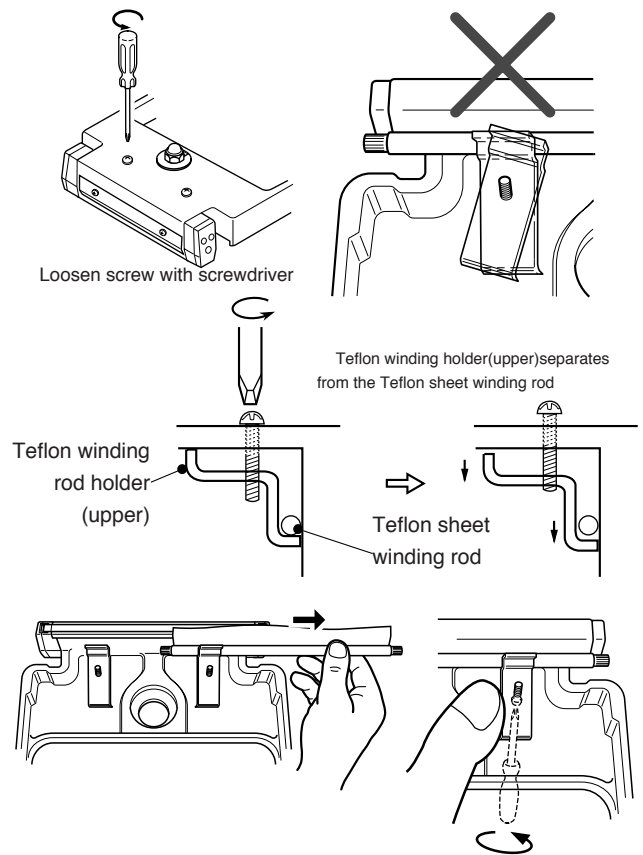

9-4 Sliding the Teflon sheet (on the lower side)

Essential tools: Scissors, Philips screwdriver

Replace when: The Teflon breaks, burns or when the seal becomes messy.

The extra Teflon sheet is rolled up to the winding rod about 25-30cm.

1. Raise pressure lever according to "9-1 Preparation".
2. Loosen plastic nuts and Teflon holding plate screws.
3. Pull out new sheet of Teflon over the heating element by pulling the ends of the Teflon.
4. Cut off excess with scissors.
5. When inserting, place ends of Teflon sheet between Teflon holding plate (lower) and frame. Secure Teflon holding plate with screws.
6. Straighten out Teflon sheet by turning Teflon winding rod.
7. Stabilize Teflon winding rod with the Teflon winding rod holder (lower) by turning the plastic nuts.

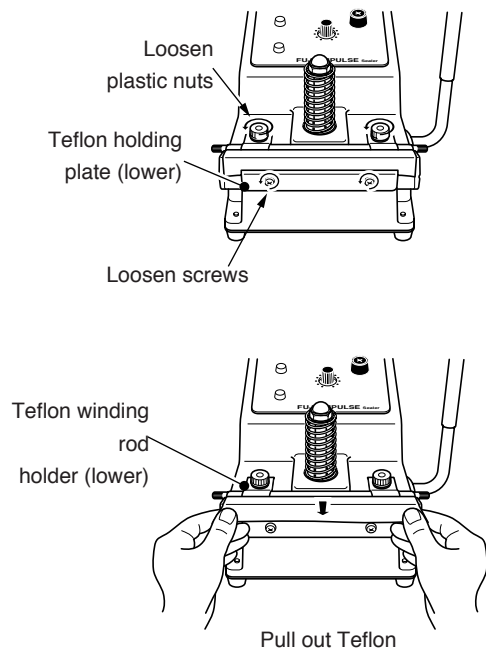

9-5 Teflon replacement (on the lower side)

Essential tools: Scissors, Philips screwdriver

Replace when: The Teflon breaks, burns or when the seal becomes messy.

Teflon sheet is sold individually or included in the maintenance parts kit. The extra Teflon sheet is rolled up to the winding rod about 25-30cm.

Attach the new Teflon sheet when all part of the Teflon sheet is used. When doing so, please be careful not to rip the Teflon sheet with the upper Teflon holding plate.

1. Raise pressure lever according to "9-1 Preparation".
2. Loosen plastic nuts and Teflon holding plate screws.
3. Pull out new sheet of Teflon over the heating element by pulling the ends of the Teflon.
4. Cut off excess with scissors.
5. When inserting, place ends of Teflon sheet between Teflon holding plate (lower) and frame. Secure Teflon holding plate with screws.
6. Straighten out Teflon sheet by turning Teflon winding rod.
7. Stabilize Teflon winding rod with the Teflon winding rod holder (lower) by turning the plastic nuts.

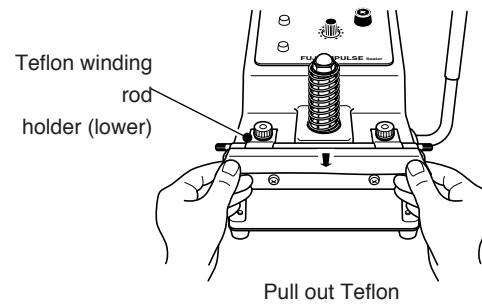
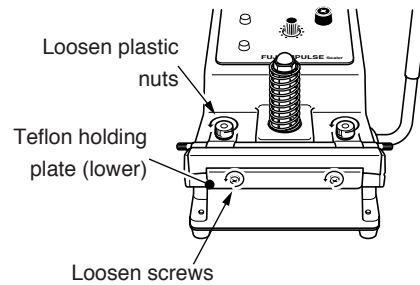

9-6 Heating element replacement (on the Lower side)

Electrodes that mount the heating element consist of parts as in the right illustration.

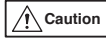

Caution When replacing heating element, check glass tape and sarcon sheet for any damage. If damaged, replace. There is a danger of a short circuit if the machine is operated with a damaged glass tape and sarcon sheet and the heating element comes into direct contact with the frame.

Essential tools: Philips Screwdriver

Replace when: Heating element breaks, unevenness is generated, or when the seal becomes messy.

Heating element is either sold individually or included in the maintenance parts kit.



Warning If for some reason you misplace screw C (M4x6), please do not use a longer screw in its place. If a longer screw is used in its place, it will come into contact with screw D and may cause a short circuit.



TIPS The machine is constructed so that the heating element may be replaced without removing the electrode cover to prevent accidental loss of any screws or the cover.

1. Remove the Teflon sheet referring to “9-4 Sliding the Teflon sheet (on the lower side).”
2. Loosen the screw B on both sides of the electrodes so the heating element is not stretched tight.
3. Insert Philips screwdriver into the hole of the electrode cover to loosen screw C and remove heating element.
4. When mounting, insert the ends of the heating element between the electrode plate and plate spring. Hold ends of heating element to prevent shifting while screwing into place.
5. Securely tighten the screw B loosened at the procedure 2 so the heating element stretches tight. If the heating element is mounted loose and not tightened enough, it may damage the heating element.

Electrode component parts

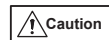
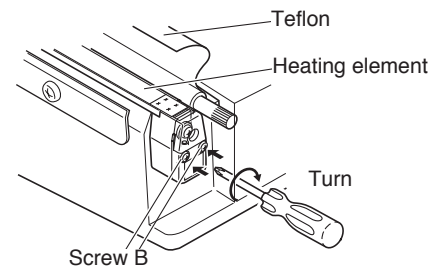
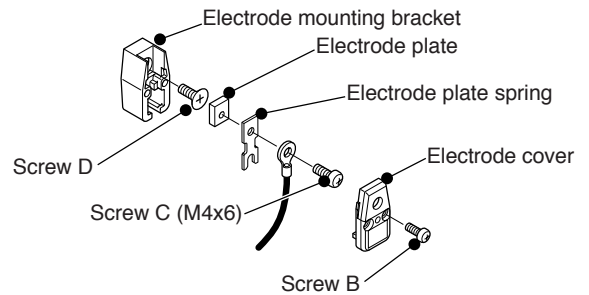

Caution Without loosening the screw B, the heating element will be kept stretched tight. Thus the heating element terminal cannot be inserted between the electrode plate and plate spring.

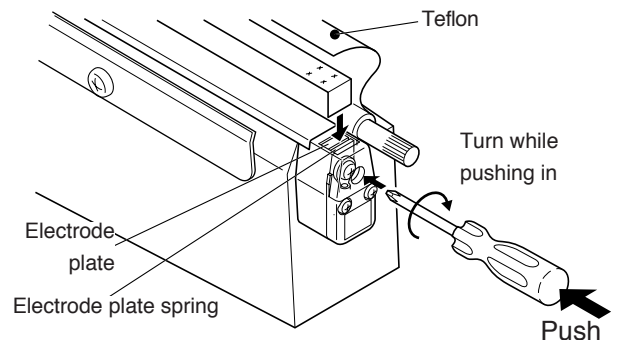

9-7 Heating element replacement (on the Upper side)



When replacing heating element, check glass tape and sarcon sheet for any damage. If damaged, replace. There is a danger of a short circuit if the machine is operated with a damaged glass tape and sarcon sheet and the heating element comes into direct contact with the frame.

Essential tools: Philips Screwdriver

Replace when: Heating element breaks, unevenness is generated, or when the seal becomes messy.

Heating element is either sold individually or included in the maintenance parts kit.



If for some reason you misplace screw C (M4x6), please do not use a longer screw in its place. If a longer screw is used in its place, it will come into contact with screw D and may cause a short circuit.



The machine is constructed so that the heating element may be replaced without removing the electrode cover to prevent accidental loss of any screws or the cover.

1. Remove upper Teflon sheet referring to “9-2 Sliding the Teflon sheet (on the upper side).”
2. Insert Philips screwdriver into the hole of the electrode cover to loosen screw C and remove heating element. There is no need to remove the electrode cover.
3. When mounting, insert the ends of the heating element between the electrode plate and plate spring. Hold ends of element to prevent shifting while securing with screw C.
4. When mounting, insert the ends of the heating element between the electrode plate and plate spring. Hold ends of heating element to prevent shifting while screwing into place.
5. Securely tighten the screw B loosened at the procedure 2 so the heating element stretches tight. If the heating element is mounted loose and not tightened enough, it may damage the heating element.

Electrode component parts

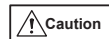
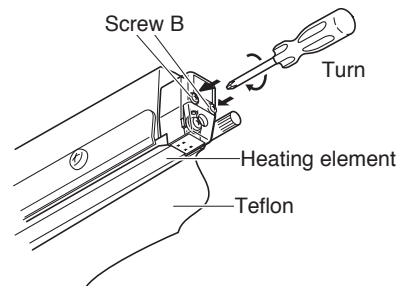
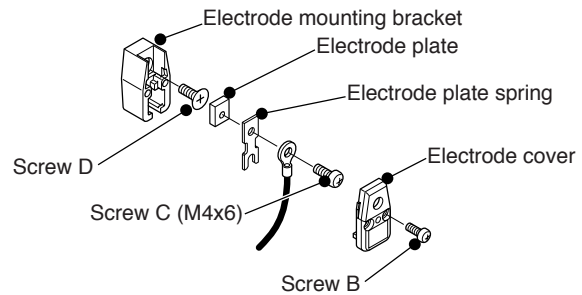

Without loosening the screw B, the heating element will be kept stretched tight. Thus the heating element terminal cannot be inserted between the electrode plate and plate spring.

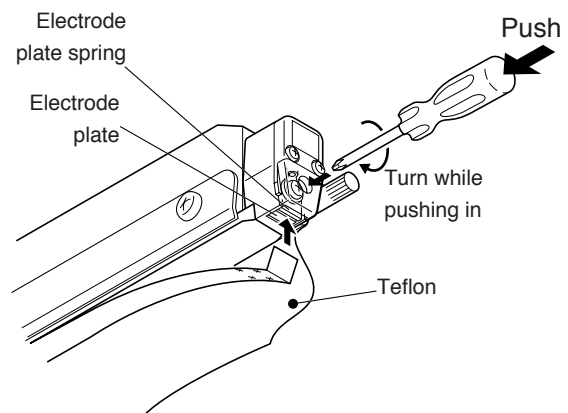

9-8 Glass tape and sarcon sheet replacement

Essential tools: Scissors, A Philips screwdriver

Replace when: The heating element breaks often, the seal becomes messy, etc.

The glass tape and Sarcon sheet are either sold individually or included in the maintenance parts kit.

1. Remove the Teflon sheet and heating element.
2. Carefully remove the glass tape (both pressure lever and frame) and sarcon sheet.

Attention! Applying the Sarcon sheet and glass tape to the surface with adhesive residues will negatively affect the sealing surface.

3. Cut the new Sarcon sheet 2mm longer than the seal area for both left and right edges and adhere it to the pressure lever side.
4. Place glass tape over the sarcon sheet on the pressure lever side. On the frame side, place glass tape over the silicone rubber. Glass tape should be about 5mm longer on each side of the sealing area (over the electrodes).

Attention! If the adhesive of the Sarcon sheet is weak when replacing the glass tape, please replace the Sarcon sheet as well.

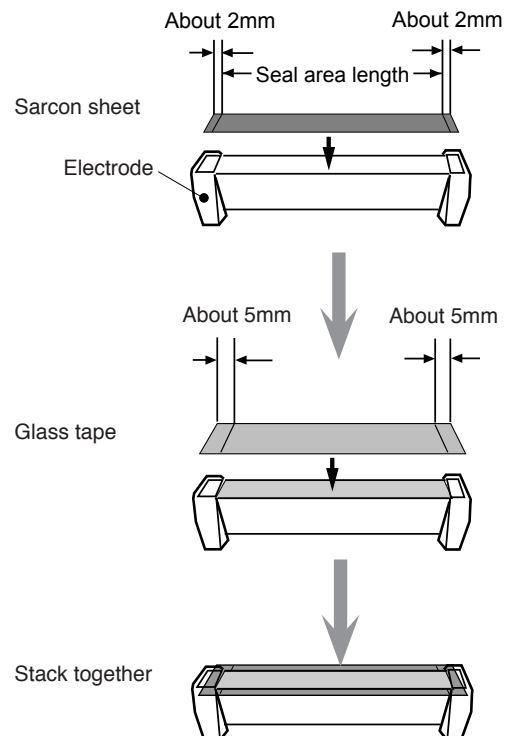

9-9 Silicone rubber replacement

Essential tools: Industrial alcohol (Ethanol)

Replace when: The seal becomes messy, etc.

The silicone rubber is either sold individually or included in the maintenance parts kit.

1. Remove Teflon and heating element according to "9-5 Teflon replacement (on the lower side)" and "9-6 Heating element replacement (on the lower side)". Peel off glass tape from the silicone rubber.
2. Remove the silicone rubber adhered to the frame body.
3. Use industrial alcohol to remove any adhesive remaining on the metal part of the sealing surface.

Attention! Applying the silicone rubber to the surface with adhesive residues will negatively affect the sealing surface.

4. Carefully place new silicone rubber starting from the edge.

Attention! Adhere the silicone rubber carefully as it cannot be reapplied.

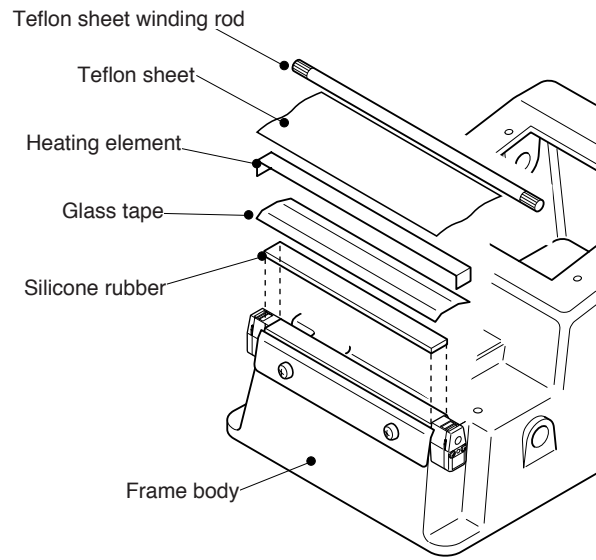

10 Adjusting the pressure adjustment nut

When shipped, the machine's sealing pressure is set to accommodate a standard bag. The appropriate sealing pressure will differ according to the type of film used and the thickness and shape of the bag. Adjust the sealing pressure according to the flow chart.

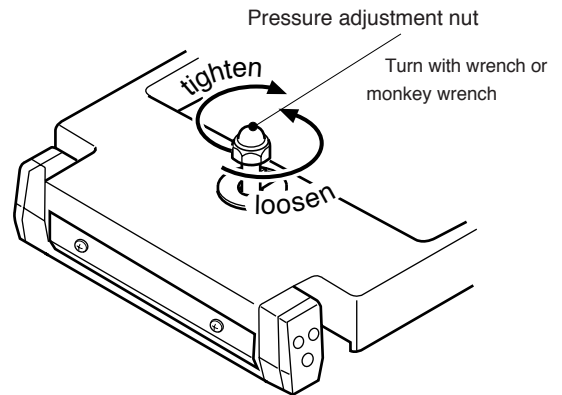

Sealing pressure adjustment procedure

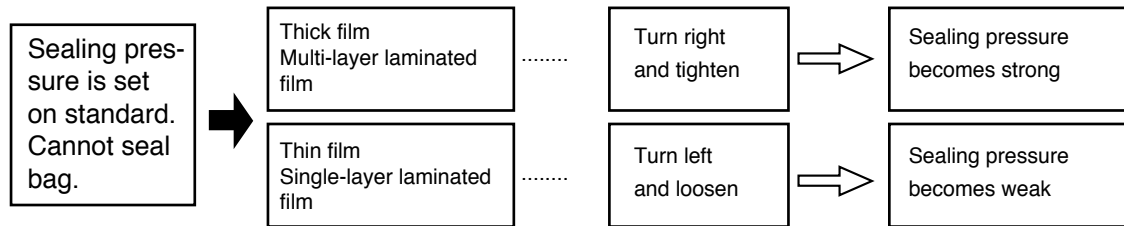

Caution If the pressure adjustment nut is over tightened, the sealing clamp will be overstressed and there is a possibility of damage to the machine. If the pressure adjustment nut is frequently tightened and loosened, the plate spring will become weak and the pressure adjustment nut may gradually loosen during sealing.